

# GSP9702 and GSP9712 Service Manual



**HUNTER**  
*Engineering Company*



# Contents

<b>1 .</b>	<b>Introduction .....</b>	<b>1-1</b>
	Purpose .....	1-1
	For Your Safety .....	1-1
	Hazard Definitions .....	1-1
	Operation .....	1-2
	Related Publications.....	1-2
<b>2 .</b>	<b>Removal / Installation / Adjustment of Components.....</b>	<b>2-1</b>
	Dataset® Arms.....	2-1
	Inner Dataset® Arm .....	2-1
	Adjustment.....	2-1
	Hall Effect Sensors .....	2-2
	Removal .....	2-2
	Installation.....	2-3
	Outer Dataset® Arm .....	2-3
	Dataset® Arm Switch, 18-396-1 .....	2-3
	Removal .....	2-3
	Installation.....	2-4
	Hall Effect Sensors .....	2-4
	Removal .....	2-4
	Installation.....	2-6
	Load Roller.....	2-7
	Removal (GSP9702) .....	2-7
	Installation (GSP9702).....	2-7
	Removal (GSP9712) .....	2-8
	Installation (GSP9712).....	2-8
	Aligning Load Roller to the Spindle.....	2-9
	Hall Effect Sensor .....	2-12
	Removal .....	2-12
	Installation.....	2-12
	Hub/Shaft Assembly, 97-397-3 (GSP9702 Only) .....	2-13
	Removal .....	2-13
	Installation.....	2-13
	Checking Runout .....	2-14
	Verifying the Hub and Spindle Taper Installation.....	2-15
	Removing the captured spring.....	2-15
	Spindle Drive Assembly, 105-406-1 (GSP9712 Only).....	2-15
	Removal .....	2-15
	Installation.....	2-16
	Console Power Supply Board (GSP9702 Only) .....	2-17
	Removal .....	2-17
	Installation.....	2-17
	Foot Pedal / Switch .....	2-18
	Removal .....	2-18
	Installation.....	2-18
	Adjustment.....	2-18
	Pneumatics .....	2-19
	Filter .....	2-19
	Air Bag, 98-334-2 .....	2-19

Removal.....	2-20
Installation.....	2-20
Interconnect Board, 45-825-1 .....	2-20
Removal.....	2-20
Installation.....	2-20
Valve Test .....	2-21
Force Transducers .....	2-22
Removal.....	2-22
Installation/Adjustment .....	2-23
Knobs Board, 45-779-1 (GSP9702 Only).....	2-24
Removal.....	2-24
Installation.....	2-26
Knob Interconnect Board, 45-953-1 (GSP9712 Only).....	2-28
Removal.....	2-28
Installation.....	2-28
Keypad, 18-383-2 (GSP9702 Only) .....	2-29
Removal.....	2-29
Installation.....	2-29
Keypad, 18-441-2 (GSP9712 Only) .....	2-31
Removal.....	2-31
Installation.....	2-31
Spindle Encoder Board, 45-863-1 .....	2-32
Removal.....	2-32
Installation.....	2-32
Adjustment.....	2-33
GSP Board, 45-715-3.....	2-34
Removal.....	2-34
Installation.....	2-34
CRT, 227-80-2 (GSP9702 Only) .....	2-35
Remove Console from Cabinet as follows:.....	2-35
Reinstall Console onto Cabinet as follows:.....	2-37
Adjustment.....	2-38
CRT Removal (GSP9702 Only) .....	2-39
Installation (GSP9702 Only) .....	2-41
Installing the Kristel Monitor Upgrade, Kit 20-1448-1 (GSP9702 Only) .....	2-42
Installing the CRT Shock Mounting Kit, 20-1447-1 (GSP9702 Only).....	2-45
CRT, 227-74-2 (GSP9712 Only) .....	2-49
Remove Console from Cabinet as follows:.....	2-49
Reinstall Console in Cabinet as follows:.....	2-49
Console Support Assembly (GSP9712).....	2-50
Removal .....	2-50
Installation .....	2-53
Printer Removal and Installation .....	2-58
Removal .....	2-58
Installation .....	2-58
Printer/Transformer Wiring Diagram.....	2-59
Program Cartridge, G01-0110000-1 .....	2-60
Removal and Installation: (GSP9702) .....	2-60
Removal and Installation: (GSP9712) .....	2-61
DC Motor Drive, 232-115-1 .....	2-62
Removal:.....	2-62
Installation.....	2-63

### **3 . Service Mode Diagnostics .....3-1**

Force Sensors.....	3-1
Rotary Encoders.....	3-4
Spindle Encoder .....	3-4
Knob Encoder(s) .....	3-5
Keys and Switches .....	3-6
Data Acquisition Circuits .....	3-6

Dataset® Arm Sensors .....	3-8
Loaded Runout Sensor .....	3-9
Diameter Accuracy Verification .....	3-9
Loaded Runout Air Components.....	3-10
DC Motor/Drive .....	3-11
<b>4 . Troubleshooting.....</b>	<b>4-1</b>
Calibration Data Error Codes .....	4-1
Understanding the Force Transducer Error Codes.....	4-1
Default calibration check values that are loaded when calibration begins...	4-1
Calibration Failure .....	4-2
3-Spin Calibration Failure.....	4-2
Inner Dataset® Arm Calibration Failure .....	4-3
Outer Dataset® Arm Calibration Failure .....	4-4
Load Roller Calibration Error Codes .....	4-6
Servo Stop Calibration Error Codes.....	4-6
Interconnect Board, 45-825-1 .....	4-7
CRT .....	4-8
Printer.....	4-8
Identifying Mechanical Mounting Repeatability Errors .....	4-8
To test mechanical mounting repeatability: .....	4-9
Data Analysis:.....	4-9
Troubleshooting Chart.....	4-10
Balance/Force Non-Repeatability Flowchart.....	4-17
<b>5 . Appendix A – Part Numbers.....</b>	<b>5-1</b>
<b>6 . Appendix B – Pneumatic System .....</b>	<b>6-1</b>
Air Component Function (GSP9702) .....	6-1
Air Component Function (GSP9712) .....	6-3
Inflation Station System Schematic.....	6-5
Fill Air Bag.....	6-5
Fill Tire .....	6-6
Read Air Bag.....	6-7
Read Tire .....	6-8
<b>7 . Appendix C – Interface Board Schematic, 1-1-297.....</b>	<b>7-1</b>
<b>8 . Appendix D - Cal Position Values and Tolerance Checks.....</b>	<b>8-1</b>



# 1 .Introduction

---

## Purpose

This manual will assist service personnel in repairing and troubleshooting the GSP9700 Series (GSP9702 and GSP9712) Vibration Control System.

---

## For Your Safety

### Hazard Definitions

Watch for these symbols:

 **CAUTION:** Hazards or unsafe practices, which could result in minor personal injury, product, or property damage.

 **WARNING:** Hazards or unsafe practices, which could result in severe personal injury or death.

 **DANGER:** Immediate hazards, which will result in severe personal injury or death.

These symbols identify situations that could be detrimental to your safety and/or cause equipment damage.

The unit power cord should be disconnected from the power source while removing or installing printed circuit boards, interconnect cables, or when removing or installing the program cartridge.

 **DANGER:** Do NOT attempt to service the DC Motor Drive. This is NOT a field serviceable item and any attempt to open the box and service it may result in severe personal injury or death.

---

## Operation

When service is requested, it is important to verify the unit is being used properly. Always check for proper AC line voltage. Voltage should be 208 volts AC – 240 volts AC.

The console, like other electrical equipment, must be grounded. When installing or servicing the GSP9700 Series Vibration Control System, check the wall receptacle ground, the balancer console ground, and the continuity of the AC power cord.

 **WARNING:** The ground pin on the AC plug must not be cut off.

Static sensitive components can easily be damaged if anti-static precautions are not observed.

 **CAUTION:** An anti-static wrist strap must be worn when servicing the console or other circuit boards to prevent damage to static sensitive components.

The console may operate erratically if connected to an outlet of a circuit shared by noisy electrical equipment, such as air compressors and large fans. If the console operates erratically in existing outlets, a dedicated line with a properly grounded outlet should be installed. For new facilities, it is recommended to plan for a dedicated line with a properly grounded outlet.

---

## Related Publications

Additional information on the GSP9700 Series Vibration Control System can be found in:

Form 4202T	Operation Instructions for the GSP9700 Series Vibration Control System (GSP9702 and GSP9712)
Form 4203T	Installation Instructions for the GSP9700 Vibration Control System (GSP9702 only)
Form 4229T	GSP9700 Calibration Instructions
Form 4505T	Installation Instructions for 120 Volt Printer for GSP9700 Kit 20-1495-1 (GSP9702 only)
Form 4780T	Installation Instructions for Inflation Station on GSP9700 Vibration Control System Kit 20-1635-1 (GSP9702 only)
Form 4972T	Installation Instructions for the GSP9712 Vibration Control System (GSP9712 only)
Form 4978T	Installation Instructions for GSP9712 Vibration Control System Printer Kit 20-1605-1 (GSP9712 only)
Form 12-12	GSP9700 Parts Drawings
Form 12-14	GSP9712 Parts Drawings



# 2 .Removal / Installation / Adjustment of Components

---

## Dataset® Arms

### Inner Dataset® Arm

The inner Dataset® arm is used to input rim dimensions and measure runout.

#### Adjustment

The inner Dataset® arm should glide freely in the grooves of the rollers along its track with a little vertical movement at the base. If it does not glide freely and seems to be binding, verify that the shaft is not marred or bent. If the preload pivot casting is putting too much pressure on the shaft, check that the stop screw is adjusted properly. There should be a 0.010 - 0.020 inch gap under the stop screw. If there is too much movement, rotate the adjustment screw clockwise to tighten the adjustment. The arm should glide freely along the track under the pressure of the spring.

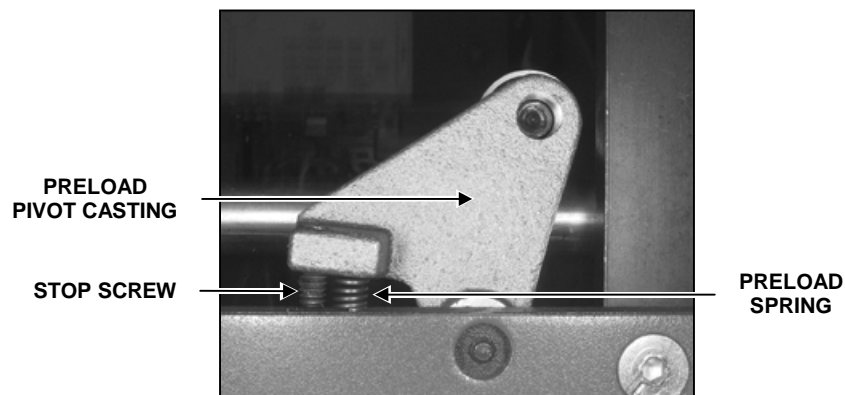

Ensure that the transducer cables do not interfere with the movement of the lateral sensor link.

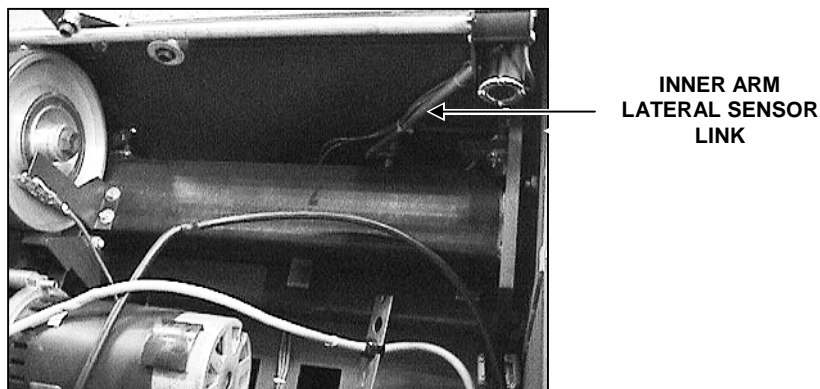

## Hall Effect Sensors

The Inner Dataset® arm has an inner radial and inner lateral Hall effect sensor.

### Removal

1. Disconnect the power cord from the power source.
2. Locate the correct Hall effect sensor for removal.



RADIAL HALL EFFECT SENSOR

THIS SCREW MUST BE INSTALLED IN THE OPPOSITE DIRECTION TO AVOID RUBBING ON THE WEIGHT TRAY

LATERAL HALL EFFECT SENSOR

3. Disconnect the sensor wire from the interconnect board, (J6 for lateral sensor, J7 for radial sensor).
4. Remove the four nuts, 76-59-2, holding the retainer, 41-112, in place.
5. Remove the retainer.
6. Gently remove the sensor, 125-299-1, by grasping the extruded plastic pin with needle nose pliers, while gently pulling on the sensor wire.

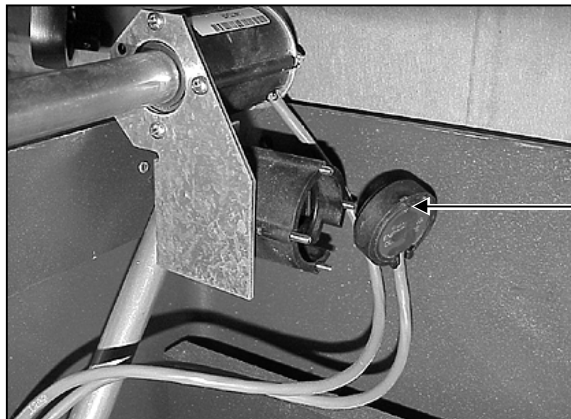

PLASTIC PIN

7. Remove the Phillips head screw, 75-508-2, from the magnet assembly, 176-35-1. Remove the magnet assembly.

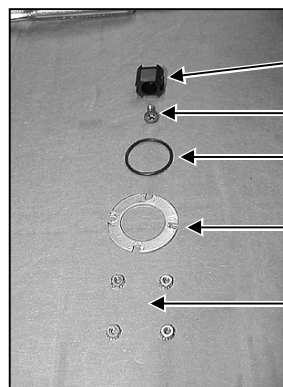

MAGNET ASSEMBLY, 176-35-1

PHILLIPS HEAD SCREW, 75-508-2

O-RING, 124-117-2

RETAINER, 41-112

NUTS, 76-59-2

## Installation

1. Place the Phillips head screw, 75-508-2, into the magnet assembly, 176-35-1. Verify the key molded in the magnet assembly is positioned into the keyway of the shaft. Tighten the Phillips head screw.
2. Place the O-ring in the opening.
3. Place the new Hall effect sensor, 125-299-1, into the opening.
4. Place the retainer into position.
5. Replace the four nuts previously removed, 76-59-2, over the retainer, 41-112, and tighten.
6. Reconnect the sensor wire to the interconnect board, (J6 for lateral sensor, J7 for radial sensor).
7. Reconnect the power cord to the power source.
8. Calibrate the GSP9700 inner Dataset® arm.

## Outer Dataset® Arm

The outer Dataset® arm is used to input rim dimensions and measure runout.

### Dataset® Arm Switch, 18-396-1

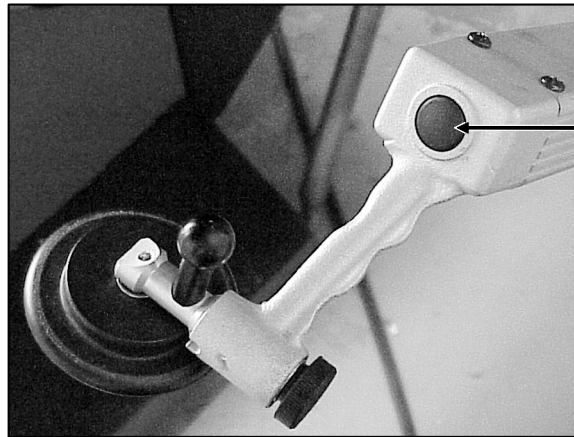

**DATASET® ARM SWITCH, 18-396-1, IS ACTIVATED BY PUSHING THIS BUTTON**

## Removal

1. Disconnect the power cord from the power source.
2. Disconnect the air supply from the GSP9700.
3. Disconnect the switch cable from the interconnect board (J11).
4. Route the switch cable out of the balancer base.
5. Pull the switch cable through the outer Dataset® shaft, 97-382-2, and the Heyco bushing, 113-201-2.
6. Remove the black spiral wrap, 70-143-2, from the outer data set arm wires.
7. Remove four screws securing the outer Dataset® arm handle, 142-113, to the outer Dataset® arm, 103-85-1.
8. Pull switch and cable through outer Dataset® arm.
9. Slide a 9/16 inch deep socket over the cable to loosen the jam nut securing the switch to the inside of the outer Dataset® arm handle.
10. After removing the jam nut, pull the cable and switch out of the outer Dataset® arm handle.

## Installation

1. Route the switch cable through the outer Dataset® arm handle from the front.
2. Slide a jam nut over the switch cable onto the backside of the switch.
3. Slide a 9/16 inch deep socket over the cable to tighten the jam nut.
4. Remove the 9/16 inch socket.
5. Route the cable through the outer Dataset® arm.
6. Reinstall the outer Dataset® arm handle into the outer Dataset® arm. Secure with four screws previously removed.
7. Route the cable through the outer Dataset® shaft and the Heyco bushing.
8. Route the switch cable into the balancer base.
9. Reconnect the switch cable to the interconnect board (J11).
10. Wrap wires with spiral wrap.
11. Reconnect the air supply to the GSP9700.
12. Reconnect the power cord to the power source.

## Hall Effect Sensors

The outer Dataset® arm contains the outer radial and outer lateral Hall effect sensors.

## Removal

1. Disconnect the power cord from the power source.
2. Locate the correct Hall effect sensor for removal.

The radial Hall effect sensor is located in the “bend” of the outer Dataset® arm.

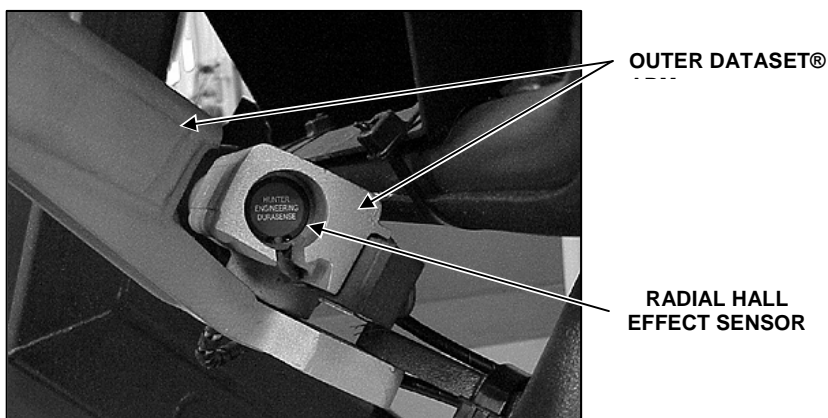

The lateral Hall effect sensor is located on the top of the outer Dataset® arm near the hood.

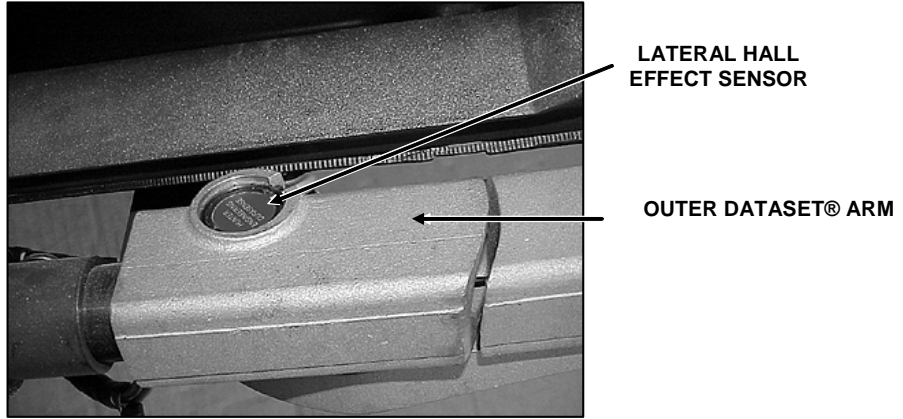

3. Remove the snap ring, 112-84-2, which is holding the Hall effect sensor, 125-299-1, in place.

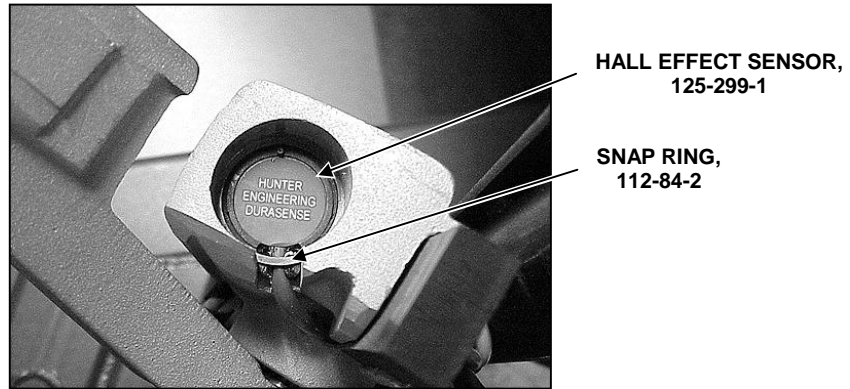

4. Remove the sensor by grasping the extruded plastic pin with needle nose pliers, while gently pulling on the sensor wire.

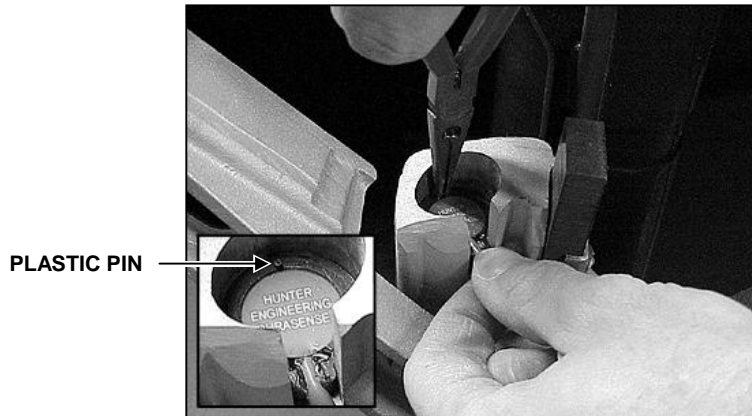

5. Remove the brass Phillips head screw, 75-508-2, from the center of the magnet assembly, 176-35-1. Remove the magnet assembly from the arm.

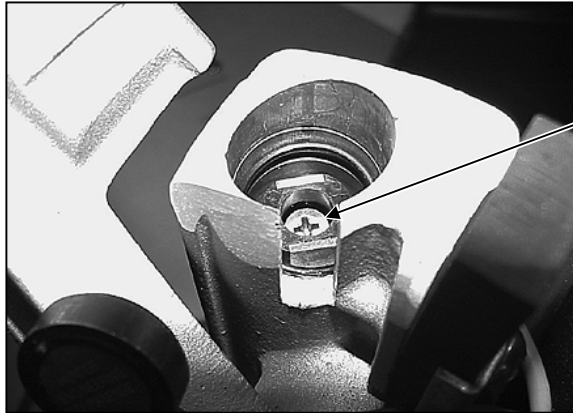

PHILLIPS HEAD SCREW,  
75-508-2

6. Remove the black spiral wrap, 70-143-2, from the outer Dataset® arm wires.



SPIRAL WRAP,  
70-143-2

7. Disconnect the sensor wire from the interconnect board, (J3 for the outer lateral sensor, J4 for the outer radial sensor).
8. Remove the wire.

### Installation

1. Route the Hall effect sensor wire through the outer Dataset® arm shaft and into the balancer base. Reinstall the black spiral wrap, 70-143-2.
2. Connect the sensor wire to the interconnect board, (J3 for the outer lateral sensor, J4 for the outer radial sensor).
3. Position the brass Phillips head screw, 75-508-2, into the center of the magnet assembly, 176-35-1. Verify the key molded in the magnet assembly is positioned into the keyway of the shaft. Tighten the screw.
4. Place the O-ring in the opening.
5. Place the new sensor, 125-299-1, into the opening.
6. Replace the previously removed snap ring, 112-84-2.
7. Reconnect the power cord to the power source.
8. Calibrate the GSP9700 outer Dataset® arm.

## Load Roller

The load roller applies force to the rotating tire to take a force variation measurement. Load roller force is applied through the air bag.

Check load roller for excessive runout with a dial indicator. Runout should be checked on the aluminum surface on both ends of the load roller.

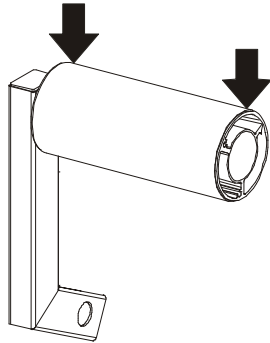

GSP9702

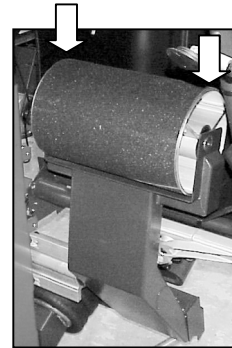

GSP9712

Any runout detected over 0.005 inch is excessive and the load roller assembly, 111-79-1 (GSP9702) or 111-99-1 (GSP9712), should be replaced.

If the load roller does not require replacement, clean any excessive rubber build-up on the non-skid tape with a wire brush and rubber buffer. Replace non-skid tape, 162-93 (GSP9702) or 162-110 (GSP9712), if necessary. To remove the used non-skid surface, peel the adhesive surface away from the roller by pulling with pliers. Use a scraper and a rubber buffing type compound to remove any adhesive remaining on the load roller before installing new non-skid tape.

<b>NOTE:</b>	If necessary, low heat may be used on the non-skid tape to assist in tape removal.
--------------	--

PULL ADHESIVE  
HERE

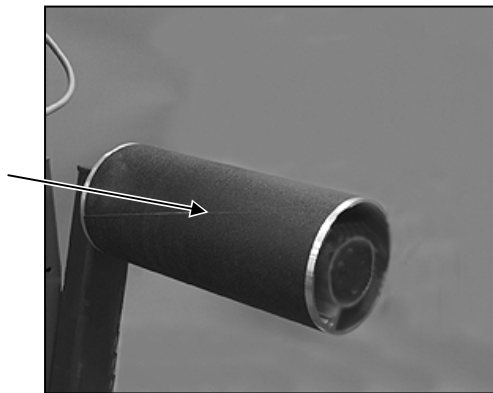

GSP9702

PULL ADHESIVE  
HERE

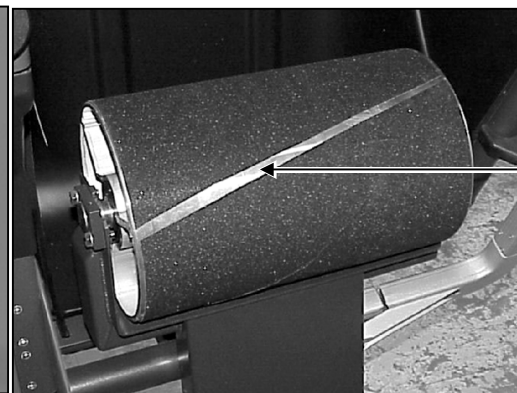

GSP9712

### Removal (GSP9702)

1. Disconnect the power cord from the power source.
2. Disconnect the air supply from the GSP9702.
3. Remove 1/2 inch bolt, 74-37-2, and 2 inch washer, 77-249-2, from the end of the load roller.
4. Remove load roller assembly.

### Installation (GSP9702)

1. Place new load roller assembly, 111-79-1, onto load roller arm.
2. Install 2 inch washer and 1/2 inch bolt onto load roller arm and tighten nut to approximately 50 ft.-lbs.
3. Reconnect power cord to the power source.
4. Reconnect the air supply to the GSP9702.

## Removal (GSP9712)

1. Disconnect the power cord from the power source.
2. Disconnect the air supply from the GSP9712.
3. Remove the two 3/8 inch bolts securing the load roller retaining block to the load roller arm.

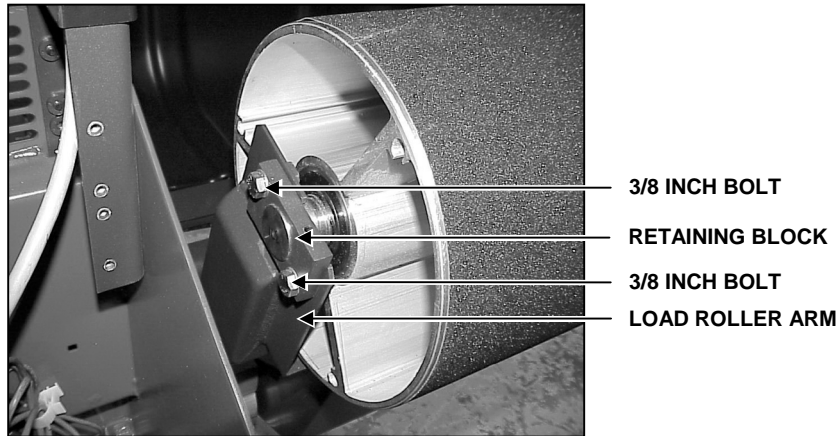

**NOTE:** Current production GSP9712 units include end caps on the load roller, however their presence does not affect removal or installation.

4. Remove the load roller retaining block.
5. Slide the load roller to the left, aligning the groove in the load roller shaft with the load roller arm.

**NOTE:** It may be necessary to use a hammer and a drift pin to drive the load roller shaft from the supports.

6. Lift the load roller up and away from the load roller arm.

## Installation (GSP9712)

1. Place the new load roller assembly onto the load roller arm.
2. Secure the load roller retaining block to the load roller arm with two 3/8 inch bolts. Tighten the two bolts to approximately 35 ft.-lbs.
3. Reconnect power cord to the power source.
4. Reconnect the air supply to the GSP9712.



## Aligning Load Roller to the Spindle

1. Loosen the four bolts from the aluminum bearing housing that secure the load roller assembly to the cabinet. The bolts must remain loose enough to allow leveling adjustments.

<b>NOTE:</b>	<b>DO NOT OVERTIGHTEN!</b> The plate on the airbag is aluminum. Over-tightening will strip out the threads in the plate.
--------------	--

2. Prior to making any adjustments, make sure the spacer nuts on the backside of the aluminum bearing housing are snug, but not tight, to the cabinet.



3. To adjust the load roller assembly, begin by loosening the adjustment screw above the aluminum bearing housing.

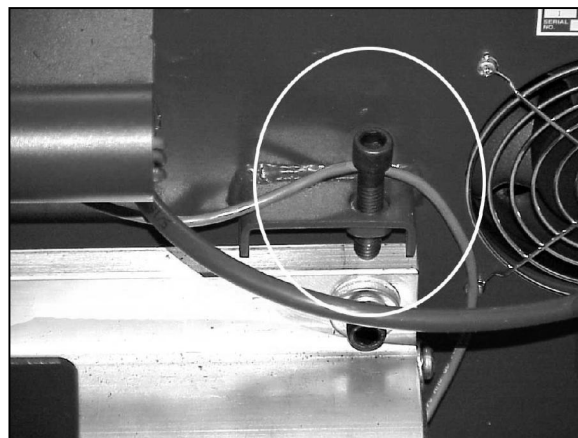

- Using a level, slowly tighten the adjustment screw until the assembly is level within 1/32".

**NOTE:**

"Level within 1/32 inch" is based upon the spindle being level also. What is most important is that the spindle and the load roller are parallel to each other. If the balancer is sitting on an out of level floor, the spindle and the load roller will not be level.

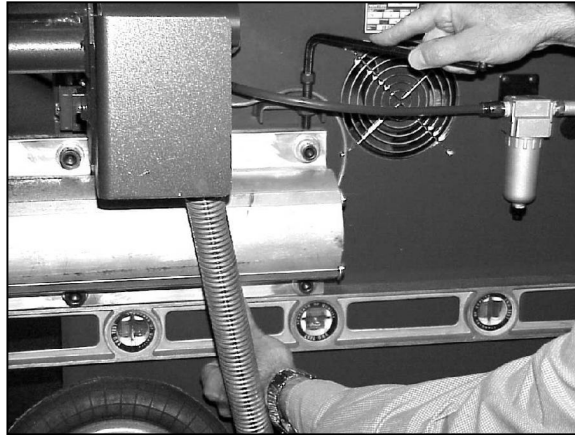

- Place the side of a carpenter's square flush against the spindle hub.

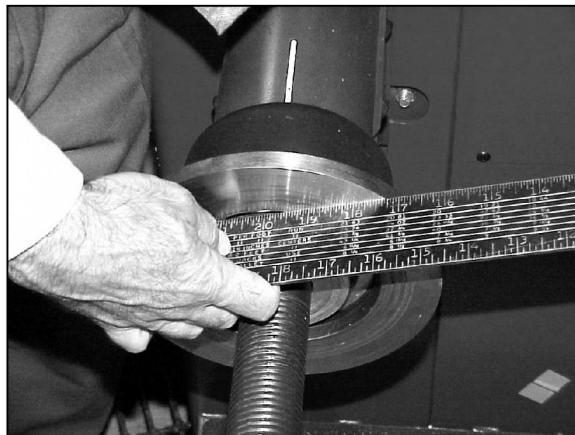

- Place the corner angle flush against the load roller.

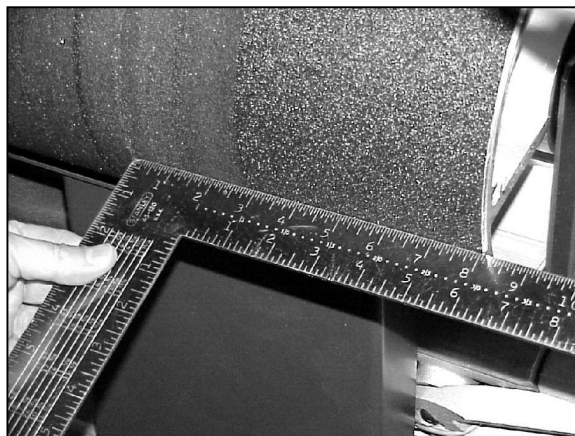

7. If the square does not sit flush or within 1/32", then adjust the angle using the spacer nuts in between the aluminum bearing housing and the cabinet. Use the open-end wrench provided with the kit. Torque the bolts as shown below with the inner two to 40 ft-lbs and the outer two to 75 ft-lbs. Recheck to make sure the load roller has not moved.

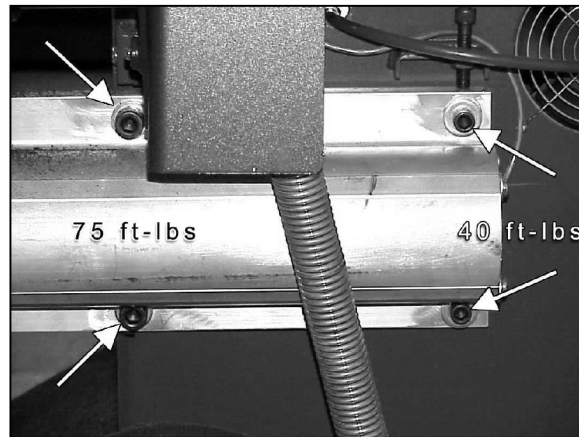

8. Thread the load roller cable through the console, and connect to the appropriate connection on the interconnect board.

## Hall Effect Sensor

The Load Roller has one Hall effect sensor located in the roller arm pivot block on the rear of the balancer.

### Removal

1. Disconnect the power cord from the power source.
2. Locate the Hall effect sensor.

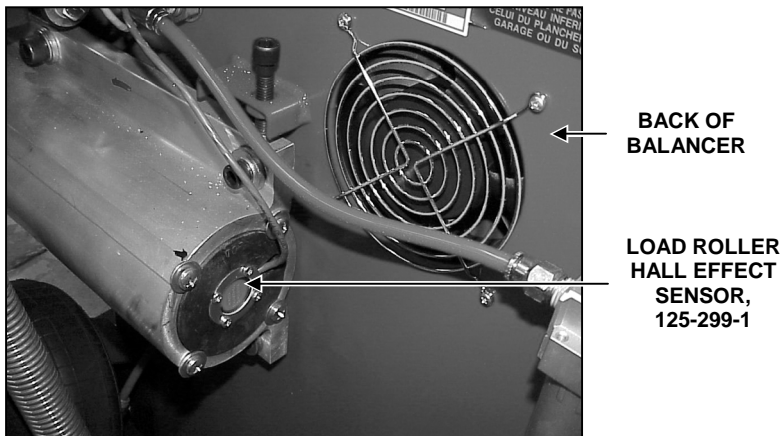

3. Disconnect the sensor wire from the interconnect board, (J2).
4. Remove the four Phillips head screws, 75-128-2, holding the retainer, 41-112, in place.
5. Remove the retainer.
6. Remove the Hall effect sensor, 125-299-1, by grasping the extruded plastic pin with needle nose pliers, while gently pulling on the sensor wire.
7. Remove the O-ring.
8. Remove the Phillips head screw, 75-508-2, from the magnet assembly, 176-35-1. Remove the magnet assembly.

### Installation

1. Place the Phillips head screw, 75-508-2, into the magnet assembly, 176-35-1. Verify the key molded in the magnet assembly is positioned into the keyway of the shaft. Tighten the Phillips head screw.
2. Position the O-ring in the opening.
3. Place the new Hall effect sensor, 125-299-1, into the opening.
4. Place the retainer into position.
5. Replace the four Phillips head screws previously removed, over the retainer and tighten.
6. Reconnect the sensor wire to the interconnect board, (J2).
7. Reconnect the power cord to the power source.

---

## Hub/Shaft Assembly, 97-397-3 (GSP9702 Only)

### Removal

1. Remove the 14mm bolt inside of the hub shaft assembly.

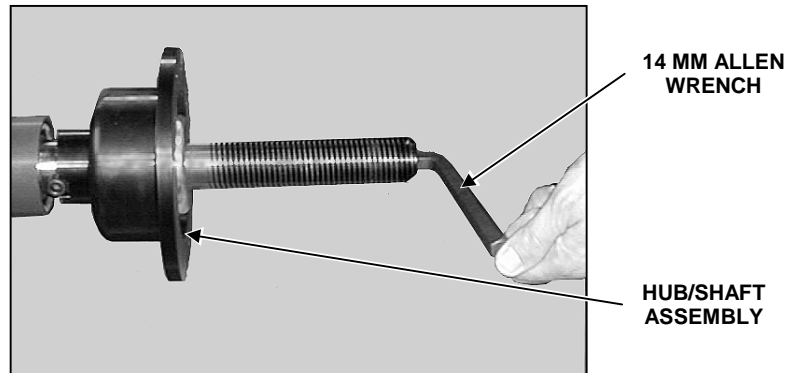

2. Remove the hub/shaft assembly from the tapered surface.

### Installation

1. Clean the taper of the spindle with a clean cloth and verify that it is free of dirt, debris, and nicks. Apply a light coat of oil to the taper.

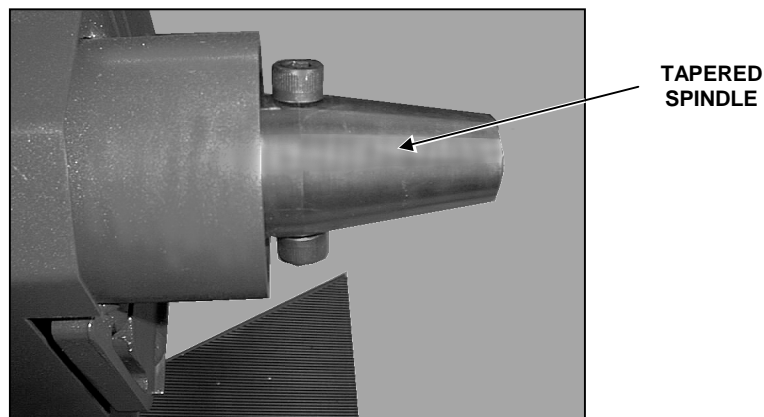

2. Position the hub/shaft assembly on the tapered surface.

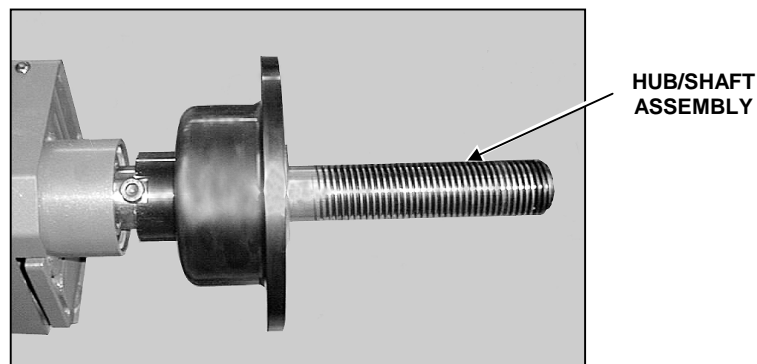

3. Seat the assembly on the tapered surface. Tighten the bolt located inside the hub/shaft assembly to approximately 50 ft-lbs.

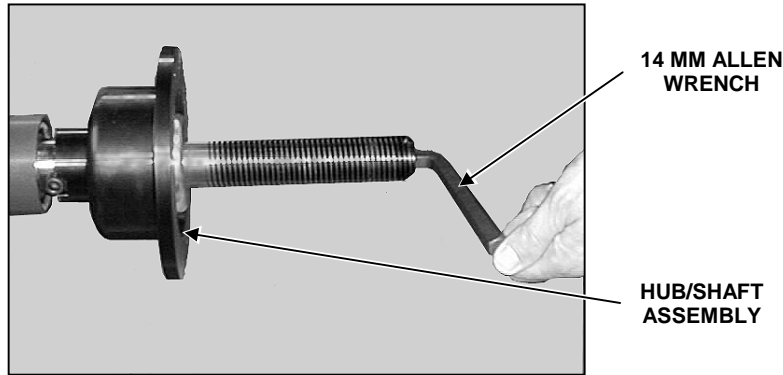

**NOTE:** Always calibrate the Balancer (3-Spin Procedure) after hub/shaft installation.

### Checking Runout

Use a dial indicator to check for runout on the hub face and on the shaft. Runout on the hub face should not exceed 0.0015 inch. Runout on the shaft should not exceed 0.0015 inch. If runout exceeds these limits, remove the threaded hub/shaft assembly and inspect for any debris or nicks on the tapered mounting surfaces. Remove any nicks by using a fine grit stone, removing only the raised portion of the metal around the nick. Do **not** use sandpaper! Clean parts and lubricate the spindle threads with a coating of light lubricant with Teflon® such as Super Lube® by Loctite after cleaning. Do not lubricate the flat, wheel hub-mounting surface. This could cause slippage between the wheel and the hub plate. Keep this surface clean and dry. When replacing or re-installing the spindle, verify proper torque of all of the related bolts.

Spindle structure bolt torque: 80 ft-lbs.

Spindle pulley bolt torque: 100 ft-lbs.

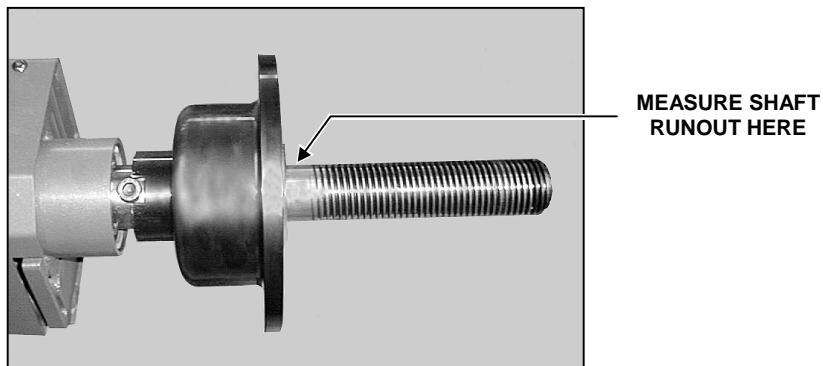

## Verifying the Hub and Spindle Taper Installation

Using a dial indicator, measure hub face and shaft runout. Mark the high spot of hub face and shaft runout. Runout on the hub face should not exceed 0.0015 inch. Runout on the shaft should not exceed 0.0015 inch. If runout exceeds these limits, remove the threaded hub/shaft assembly and inspect for any debris or nicks on the tapered mounting surfaces.

Using a block of wood and a hammer or a soft face hammer, hit the outer end of the spindle.

Remeasure hub face runout and mark the location of the high spot.

If the high spot is unchanged, the spindle and hub tapers are OK.

If the high spot has moved, inspect the spindle and hub for nicks, burrs, etc.

## Removing the captured spring

If the plate that the mounting cones push against is worn, or if the Haweka (black) portion of the spindle hub is loose, it will be necessary to replace the plate.

To remove the plate and spring, a stack of small cones is placed on the shaft. The wing nut (without the cup) is tightened until there is enough room to grab the snap ring with a pair of pliers or similar tool.

Once the snap ring is out, the wing nut is loosened slowly and the spring and plate are removed.

After the plate and spring are out, the “adaptor” bolts that secure the adaptor between the hub/spindle and the spindle taper can be removed, cleaned, and reinstalled with Loctite.

Reinstall the plate and spring on the spindle shaft. Using a stack of small cones placed on the shaft, tightening the wing nut will push the plate back into proper position. Install the snap ring, and then remove the wing nut and cones.

---

## Spindle Drive Assembly, 105-406-1 (GSP9712 Only)

### Removal

1. Remove the drive belt from the pulley, 107-107-1.
2. Remove the bolt securing the pulley to the spindle drive assembly, 105-406-1.
3. Remove three screws securing the spindle encoder bracket, 14-982-1, to the inside of the balancer. Set the spindle encoder bracket aside. *Refer to “Spindle Encoder Board,” page 2-32.*

4. Remove the washer, 77-66-2, spindle encoder disk, 17-67-2, and the pulley from the taper of the spindle drive assembly.

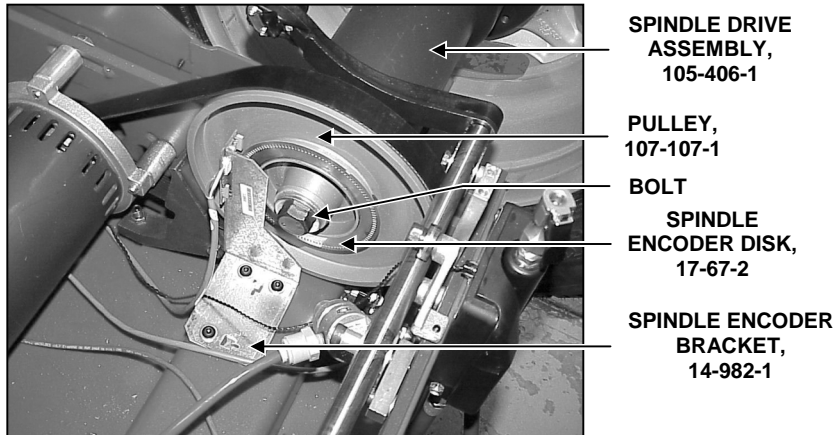

5. Remove the four socket head cap screws, 74-43-2, securing the spindle drive assembly to the support.
6. Lift the spindle drive assembly from the support.

### Installation

1. Clean the taper of the spindle drive assembly with a clean cloth and verify that it is free of dirt, debris, and nicks. Apply a light coat of oil to the taper.
2. Position the spindle drive assembly on the support.

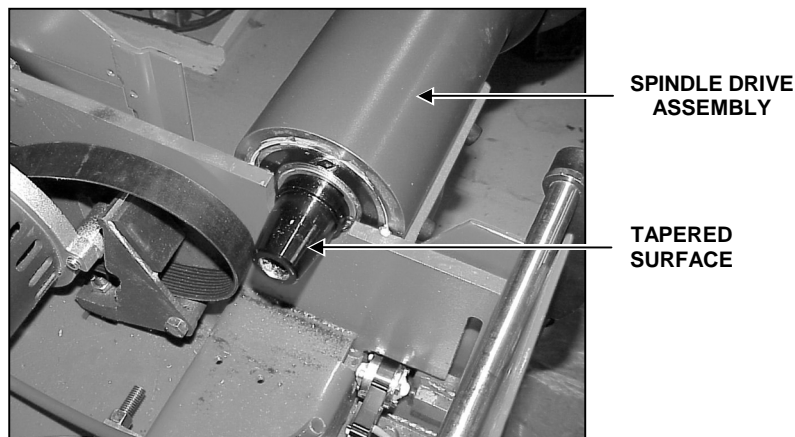

3. Reinstall the four socket head cap screws previously removed, securing the spindle drive assembly to the support.
4. Slide the pulley, the spindle encoder disk, and the washer onto the tapered surface of the spindle drive assembly. Thread the bolt into the end of the spindle drive assembly. Tighten the bolt to approximately 100 ft-lbs.
5. Secure the spindle encoder bracket to the inside of the balancer with the three screws previously removed.

**NOTE:** Always calibrate the Balancer (3-Spin Procedure) after spindle drive assembly installation.



## Console Power Supply Board (GSP9702 Only)

The power supply, 232-90-2, is located in the CRT console. This 25 watt power supply provides +5v and  $\pm 12v$  outputs.

The power supply is a non-serviceable item. Replace all failed units.

### Removal

1. Disconnect the power cord from the power source.
2. Disconnect the black cable leading to the GSP Board.
3. Disconnect the AC power supply 3-pin connector.
4. Remove the green ground wire connector from the board.

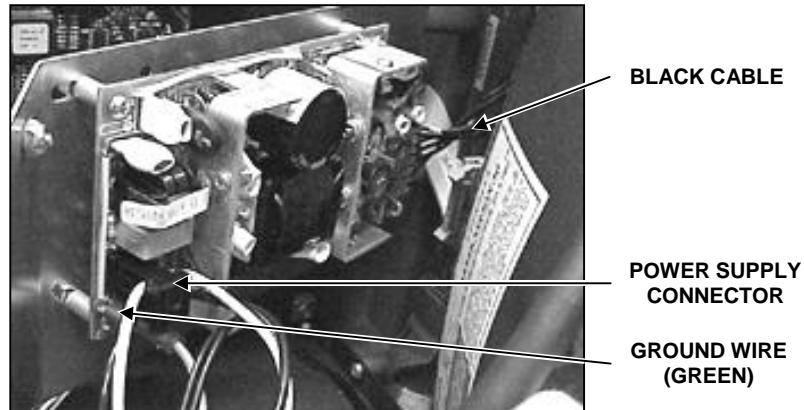

5. Remove the four Phillips head screws holding the power supply board to the metal backing plate.

### Installation

1. Replace the four Phillips head screws holding the power supply board to the metal backing plate.
2. Reconnect the green ground wire connector.
3. Reconnect the power supply 3-pin connector.
4. Reconnect the black cable connector.
5. Reconnect the power cord to the power source.
6. Calibrate the GSP9702.

When checking the power supply output voltages, use the test pads located on the GSP Board. Voltages should check within  $\pm 5\%$ .

#### TEST PADS

+12  
+5A  
+5 (GENERATED ON GSP BOARD)  
-12  
-5 (-5 ANALOG, GENERATED ON GSP BOARD)  
GND (GROUND)

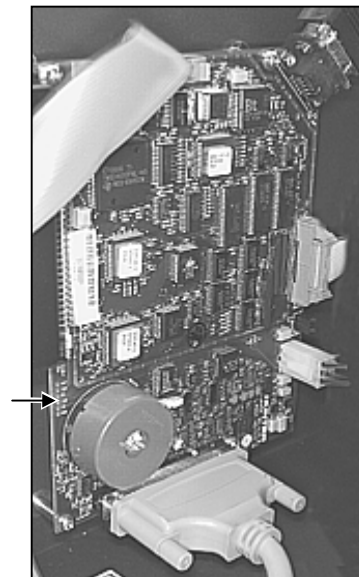

---

## Foot Pedal / Switch

The foot pedal is used to enter rim dimensions, begin/reverse Quick-Thread® motion, and is used as a brake for final tightening of the wingnut.

### Removal

1. Disconnect the power cord from the power source.
2. Disconnect the wire connector from the switch.

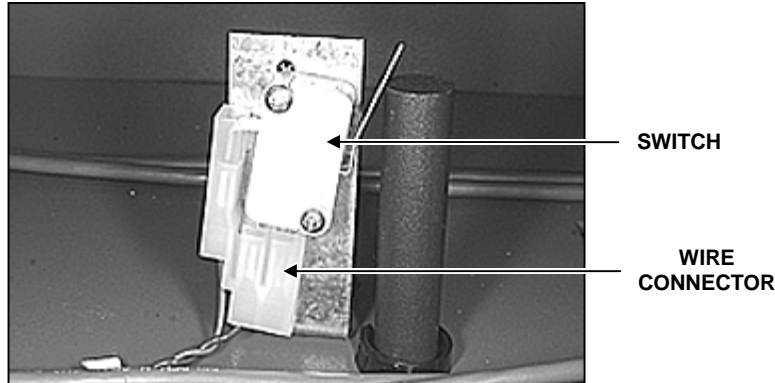

3. Remove the Phillips head screws that connect the switch to the base of the GSP9700.

### Installation

1. Install new switch into the base of the GSP9700 and install the two Phillips head screws previously removed.
2. Reattach the wire connector to the switch.
3. Reconnect the power cord to the power source.
4. Verify proper use. Refer to "Adjustment."

### Adjustment

To adjust the foot pedal, loosen the screws at the base of the switch and move the switch closer to the foot pedal rod. Tighten the screws while holding the switch in its new position. Adjust the switch position if necessary so it switches simultaneously or just before the Spindle-Lok® pad contacts the drive pulley.

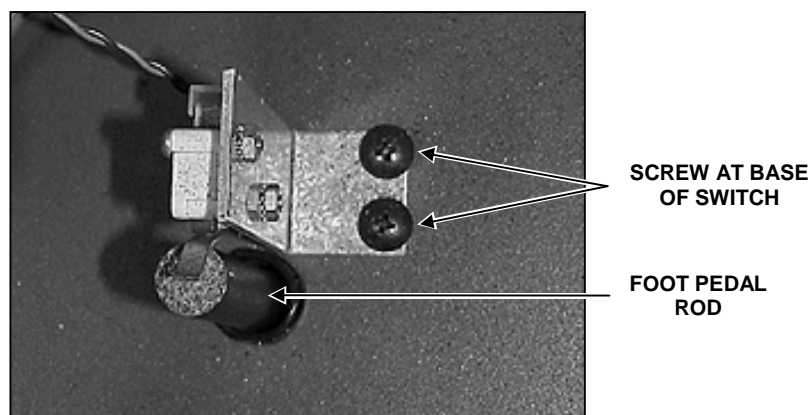

If the switch is out of travel, bend the metal contact until a good connection is made with the foot pedal rod.

<b>NOTE:</b>	Be careful to not bend the metal too much, to prevent it from becoming fragile.
--------------	---

## Pneumatics

Pneumatic lines and valves are used to inflate and deflate the air bag that applies pressure to the load roller for force variation measurements. If an air pressure error occurs, the air pressure can be checked from the Diagnostics (Service Mode) screen. Refer to "Appendix B," for more detail.

### Filter

The filter element located inside the pneumatic filter on the rear of the balancer must be kept clean. Cleaning interval is dependent upon shop conditions. The filter will automatically drain water and oil out of the bottom of the filter bowl. To remove the filter element, unscrew the filter bowl from the upper filter body.

**NOTE:** If a properly maintained air supply is in use, the required maintenance of the pneumatic system will be decreased substantially.

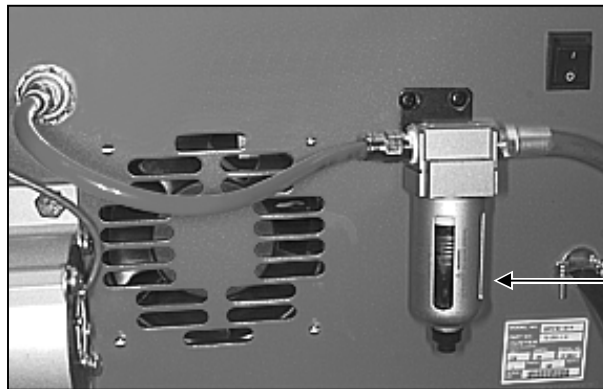

### Air Bag, 98-334-2

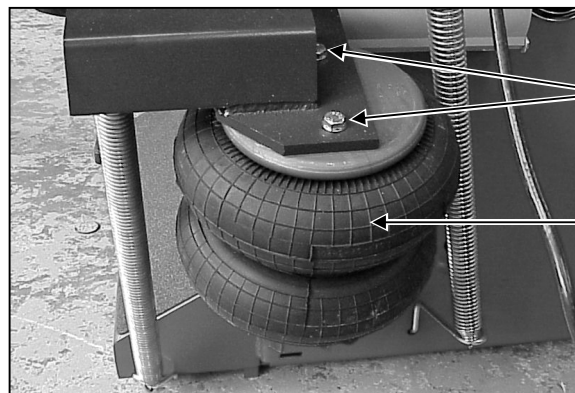

GSP9702

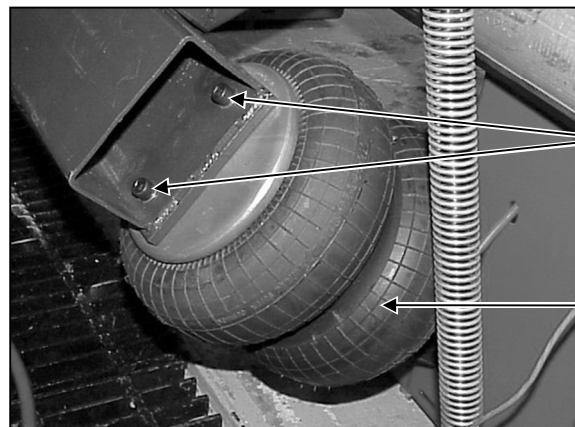

GSP9712

## Removal

1. Remove the air supply from the GSP9700.
2. Disconnect the power supply from the power source.
3. Remove the two upper bolts and washers from the top of the air bag.
4. Remove the two lower bolts and washers from the bottom of the air bag.
5. Remove the air bag assembly.

## Installation

1. Align the lower air bag mounting holes with the air bag bracket and replace the two washers and bolts previously removed.
2. Align the upper mounting holes with the air bag bracket and replace the two washers and bolts previously removed.
3. Reconnect the air supply to the GSP9700.
4. Reconnect the power supply to the power source.
5. Verify proper air bag operation.

---

## Interconnect Board, 45-825-1

The Interconnect Printed Circuit Board assembly connects force sensors, Hall effect sensors, hood switches, and DC motor drive to the GSP Board. It also provides drive outputs for the air valves and contains an air pressure sensor.

The interconnect board is not field serviceable. Exchange all failed boards. Refer to "Troubleshooting Chart," page 4-10 for identifying interconnect board problems.

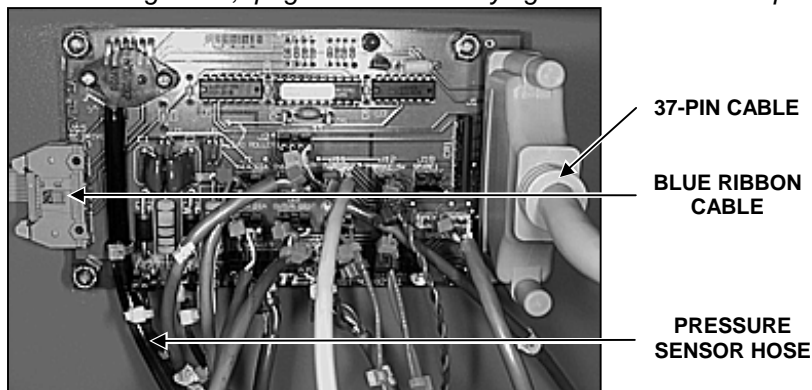

## Removal

1. Disconnect the power cord from the power source.
2. Disconnect the air supply from the GSP9700.
3. Disconnect all wires from the interconnect board.
4. Disconnect the blue ribbon cable from the interconnect board.
5. Disconnect the pressure sensor hose from the four way air inlet.
6. Disconnect the 37-pin console cable from the interconnect board.
7. Remove the four nuts from the interconnect board.

## Installation

1. Install the four nuts attaching the interconnect board to the GSP9700 base.
2. Connect the pressure sensor hose to the four way air inlet.
3. Install the blue ribbon cable from the DC Motor Drive to the interconnect board.
4. Install the 37-pin console cable onto the interconnect board.
5. Reattach all wires using the following chart.

The connecting wires are marked by tie-raps of various colors. The colors for each connector are as follows:

CONNECTOR	TIE-RAP COLORS	LOCATION
Load Roller	White (single)	J2
Outer Dataset® Arm Distance	Orange-Orange	J3
Outer Dataset® Arm Diameter	Orange (single)	J4
Inner Dataset® Arm Distance	Red-Red	J6
Inner Dataset® Arm Diameter	Red (single)	J7
“Hold-Exhaust Air” Valve	Yellow (single)	J8
“Add Air” Valve	Yellow-Yellow	J9
Hood Up	Orange-Blue	J10
Outer Dataset® Arm Switch	Red-Green	J11
Brake	Red-Blue	J12
Left Force Transducer	Yellow-Green	J13
Right Force Transducer	Yellow-Blue	J14
Spindle	Orange-Purple	J16
Hood Down	Orange-Green	J17
Spare	Red-Purple	J18

6. Reconnect the power cord to the power source.
7. Reconnect the air supply to the GSP9700.

### Valve Test

Recent interconnect boards include a test pad labeled “Valve Test.” If this pad is present, you may test a valve by connecting a jumper from the diode anode (the end without the silver band) located immediately above the connector of the valve being tested and to the “valve test” pad. The valve will turn on, if the valve being tested is not defective.

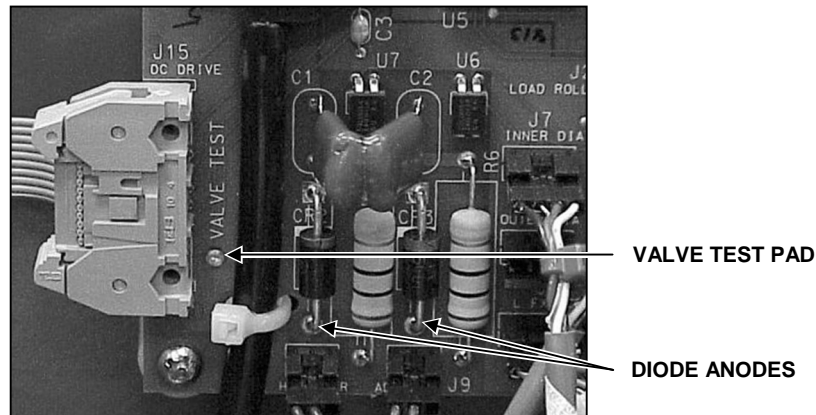

---

## Force Transducers

The Force Transducers attach to the left and right side of the balancer frame.

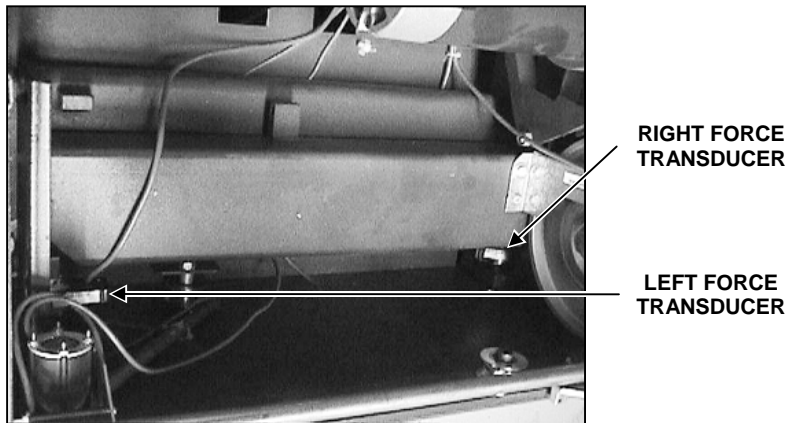

GSP9702

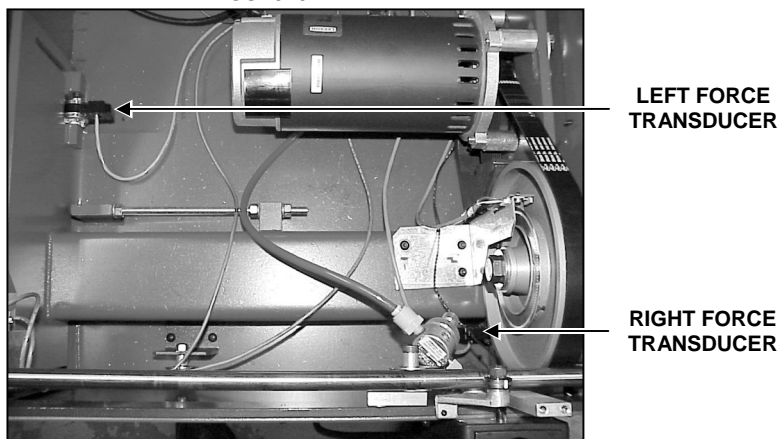

GSP9712

### Removal

1. Disconnect the force transducer from the interconnect board (Left Force Transducer – J13, Right Force Transducer – J14).
2. Loosen the setscrew until transducer is loose.
3. Remove the transducer.

## Installation/Adjustment

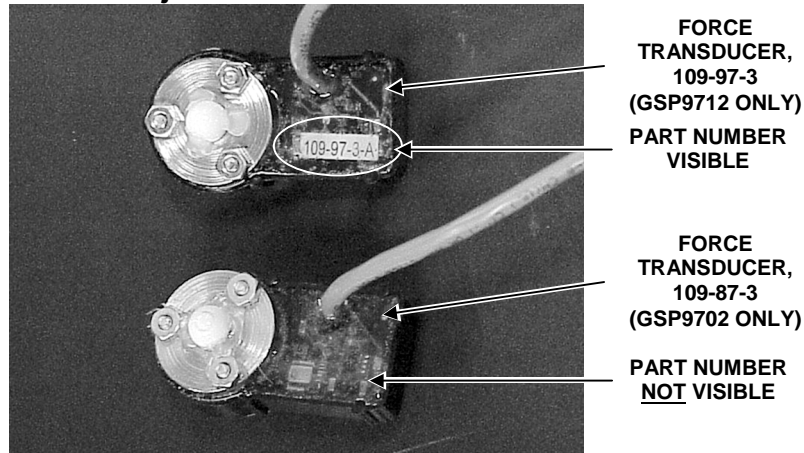

**NOTE:** Use force transducer, 109-87-3, in GSP9702 balancers only. Use force transducer, 109-97-3, in GSP9712 balancers only. The force transducers are NOT interchangeable.

Ceramic balls are glued to the transducer to aid in assembly at the factory. On early models that are not glued, the ceramic balls may be held in place with a small amount of all-purpose grease during assembly.

1. Clean the mounting surfaces so that the ball sockets and ceramic balls are completely free of any dirt or debris. Install the new transducer, making sure that the flat surface area of the ball is not contacting the ball seat. Note that later production balls do not have a flat around the middle.

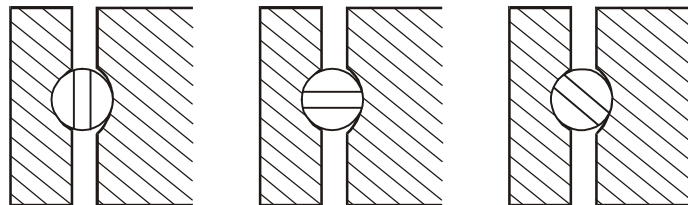

2. Place the right transducer in position and tighten the setscrew slowly, until the transducer holds in place with no looseness.
3. Place the left transducer in position and tighten the setscrew slowly, until the transducer holds in place with no looseness.

**NOTE:** This is the setscrew starting position for the left and right transducers. When replacing either transducer, it is important to re-adjust both transducers at the same time.

4. Starting with either transducer, tighten the setscrew 1/4 turn.
5. Move the transducer in small arcs to allow the ball and transducer to properly seat. Position the assembly so that the long edge of the transducer is parallel with the floor (excessive angle will cause the transducer to contact the structure, upsetting the imbalance vibration readings). Repeat this procedure for the second transducer.
6. On the first transducer, tighten the setscrew another 1/4 turn, then tighten the setscrew on the second transducer another 1/4 turn.
7. Reconnect the left force transducer to J13 on the interconnect board.
8. Reconnect the right force transducer to J14 on the interconnect board.
9. Recalibrate the GSP9700. (3-spin cal procedure)

## Knobs Board, 45-779-1 (GSP9702 Only)

The knobs board combines the knob encoder signals and keypad signals into one cable output to the GSP Board. The knobs board receives the signals from the keypad, 18-383-2, through the keypad ribbon cable connected to the end of the knobs board.

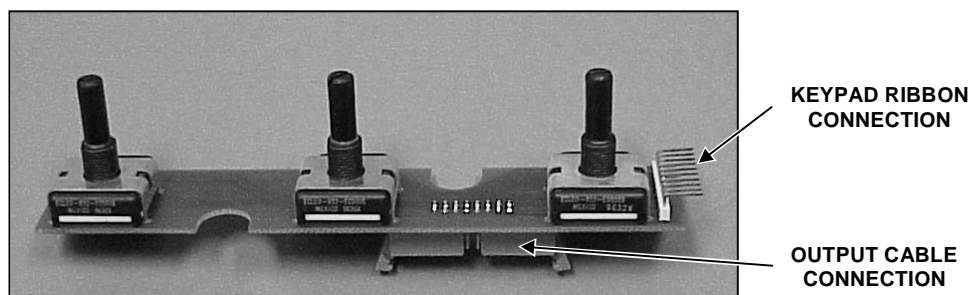

### Removal

1. Disconnect the power cord from the power source.
2. Remove the back cover from the console.
3. Disconnect the cable from the end of the knobs board by gently pulling down on the plastic end of the ribbon cable.

#### NOTE:

It is important to observe the direction of attachment during removal. The keypad cable is notched on one side, however will attach in either direction. For proper operation, the cable **must** be reattached in the direction as shown below.

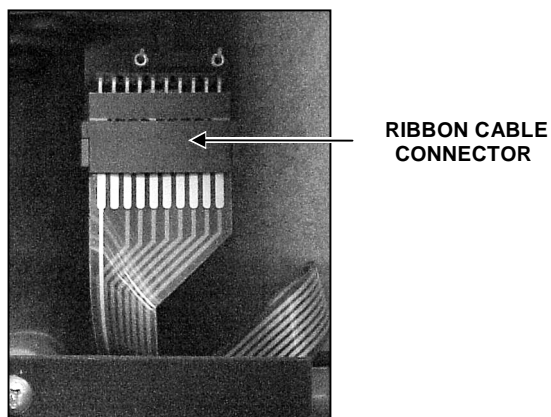

4. Disconnect the cable that connects the knobs board to the GSP board.



5. Remove three knob caps, 34-87-2, from the knobs by inserting a thin screwdriver between the knob and cap and then gently prying the cap off the knob.

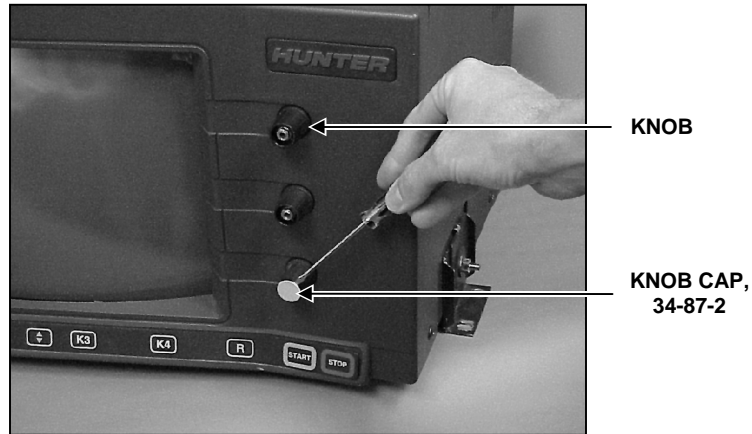

6. Remove the outer knob assembly by turning the nut counterclockwise while holding the knob. Repeat for the two remaining knobs.



7. Remove the inner knob nut by turning the nut counterclockwise. After the nut is removed, remove the inner washer from the knob spindle. Repeat for the two remaining knobs.

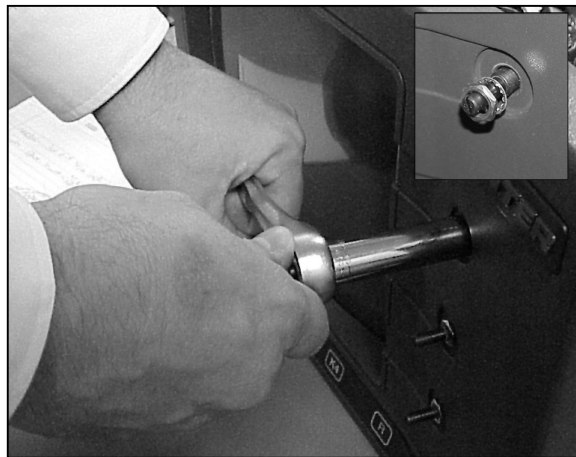

8. Remove the knobs board from the console.

## Installation

1. Place the knobs board into the console with the connection prongs for the keypad ribbon cable in the downward position.

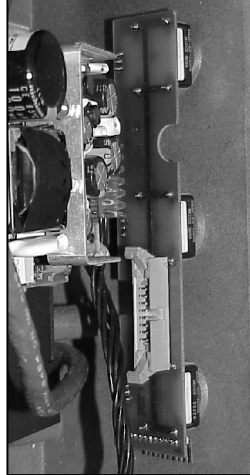

2. Place the inner knob washer on the knob spindle. Place the nut on the knob spindle. Gently tighten the nut by turning it clockwise, being careful to not overtighten the nut on the plastic threads. Repeat for the two remaining knobs.

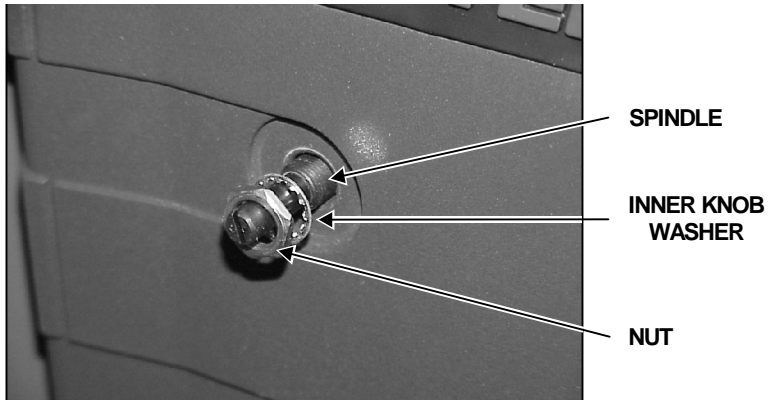

3. Place the knob on the knob spindle. Tighten the nut on the spindle by turning it clockwise while holding the knob in position. Repeat for the two remaining knobs.

**NOTE:**

When tightening the brass nut, the knob will tend to tighten itself against the bezel. To prevent binding, maintain a space (about the thickness of a piece of paper) between the knob and the console while tightening the brass nut.



4. Replace the knob cap on the knob by centering the cap on the knob and gently applying pressure in the center until the cap is in place. Repeat for the two remaining knobs.
5. Inside the console, connect the cable from the keypad to the knobs board by aligning the prongs with the cable receptor and gently pressing upward.

<b>NOTE:</b>	It is important to observe the direction of attachment during removal. The keypad cable is notched on one side, however will attach in either direction.
--------------	--

6. Reconnect the blue ribbon cable that leads from the knobs board to the GSP board.
7. Reconnect the power cord to the power source.
8. Verify that the knobs work properly and turn freely without binding.
9. Verify proper operation of the keypad.

---

## Knob Interconnect Board, 45-953-1 (GSP9712 Only)

The knob interconnect board provides connection paths for the keypad and the knob encoder/switch signals to the GSP board, and converts the 37-pin Dsub to a right angle configuration for the 9712 console.

### Removal

1. Disconnect the power cord from the power source.
2. Remove the monitor and the top cover from the CRT support console.
3. Disconnect the blue ribbon cable from J4 of the knob interconnect board.

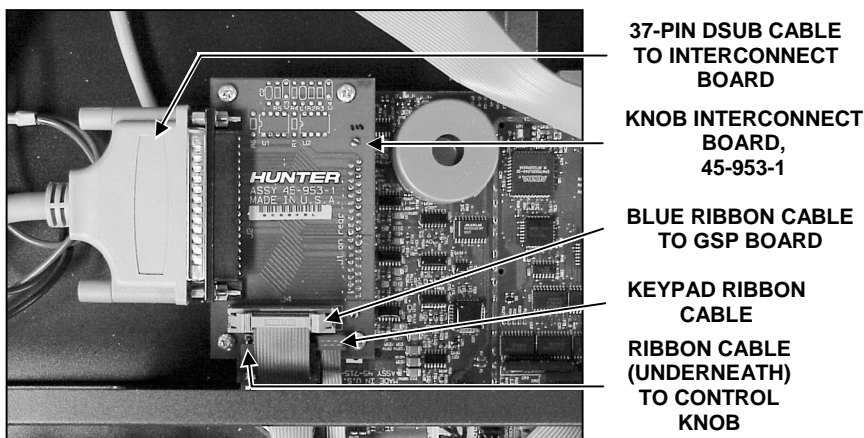

4. Disconnect the keypad ribbon cable.
5. Disconnect the ribbon cable that connects to the control knob.
6. Disconnect the 37-pin cable that connects to the interconnect board.
7. Remove four screws that secure the knob interconnect board to the GSP board, 45-715-3.
8. Lift the knob interconnect board off the connection to the GSP board.

### Installation

1. Reconnect the knob interconnect board to the connection to the GSP board.
2. Secure the knob interconnect board with the four screws previously removed.
3. Reconnect the 37-pin cable from the interconnect board.
4. Reconnect the ribbon cable from the control knob.
5. Reconnect the keypad ribbon cable.
6. Reconnect the blue ribbon cable to J4.
7. Reinstall the top cover onto the CRT support console. Reinstall the monitor.
8. Reconnect the power cord to the power source.

## Keypad, 18-383-2 (GSP9702 Only)

Operation of the GSP9702 Vibration Control System is provided by input from the numeric keypad.

The keypad consists of a membrane switch with self-adhesive backing and a hardwired ribbon cable.

The keypad is not field serviceable. Replace all failed units. The keys on the keypad are arranged as "columns" and a ground. When a key is pressed, it connects a column to the ground.

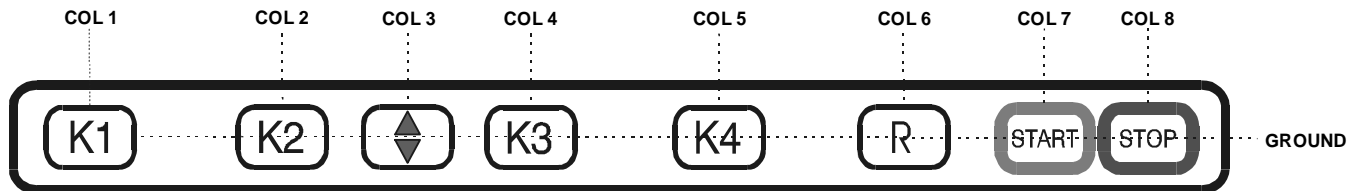

### Removal

1. Disconnect the power cord from the power source.
2. Disconnect the keypad cable from the knobs board, 45-779-1, by gently pulling down on the ribbon cable connector.
3. Using a thin screwdriver, gently pry an edge of the keypad off the GSP console.

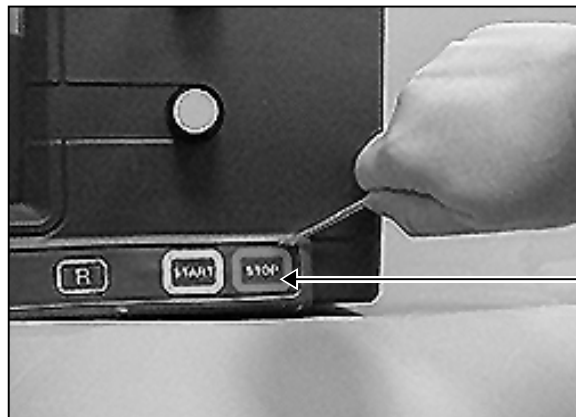

4. Remove the keypad.
5. Remove any adhesive remaining on the console with mineral spirits.

### Installation

1. With the new keypad right side up, thread the new keypad cable through the access hole to the knobs board, 45-779-1.

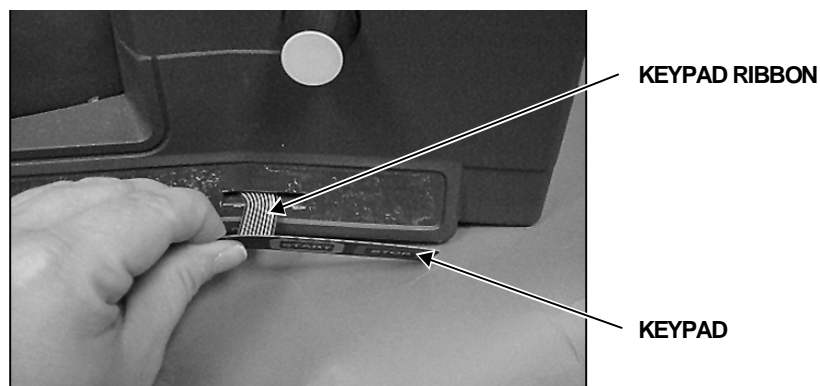

2. Before removing the adhesive backing on the keypad, verify that the keypad is orientated properly.
3. Align and attach the keypad to the console.
4. Attach the keypad cable to the knobs board.

**NOTE:**

It is important to observe the direction of attachment during removal. The keypad cable is notched on one side, however will attach in either direction. For proper operation, the cable **must** be reattached in the direction as shown below.

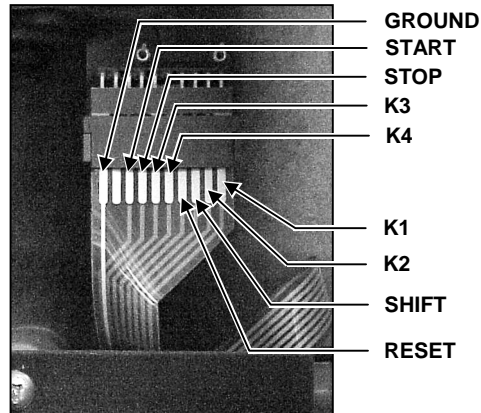

5. Reconnect the power cord to the power source.
6. Turn the GSP9702 Vibration Control System on and test the keypad to verify it is working properly.

---

## Keypad, 18-441-2 (GSP9712 Only)

Operation of the GSP9712 Vibration Control System is provided by input from the numeric keypad.

The keypad consists of a membrane switch with self-adhesive backing and a hardwired ribbon cable.

The keypad is not field serviceable. Replace all failed units. The keys on the keypad are arranged as “columns” and a ground. When a key is pressed, it connects a column to the ground.



### Removal

1. Disconnect the power cord from the power source.
2. Using a thin screwdriver, gently pry an edge of the keypad off the GSP console.
3. Remove the keypad.
4. Remove any adhesive remaining on the console with mineral spirits.

### Installation

1. Before removing the adhesive backing on the keypad, verify that the keypad is orientated properly.
2. Align and attach the keypad to the console.
3. Attach the keypad cable to the knob interconnect board.
4. Reconnect the power cord to the power source.
5. Turn the GSP9712 Vibration Control System on and test the keypad to verify it is working properly.

---

## Spindle Encoder Board, 45-863-1

There are three LED's on the spindle encoder. These LED's signal that the opto-interruptors on the LED board are working as the spindle is turning.

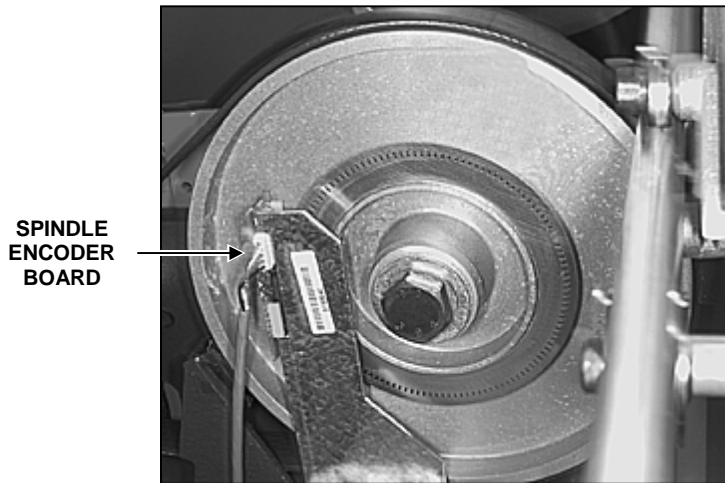

### Removal

1. Disconnect the power cord from the power source.
2. Disconnect the signal cable from the spindle encoder board.
3. Remove the two Phillips head screws from the spindle encoder board.
4. Remove the board.

### Installation

1. Align the new spindle encoder board with the screw mounting holes.
2. Reinstall the two Phillips head screws into the spindle encoder board.
3. Connect the signal cable from the interconnect board to the spindle encoder board.
4. Reconnect the power cord to the power source.



## Adjustment

1. Locate the spindle encoder board adjustment bolts.

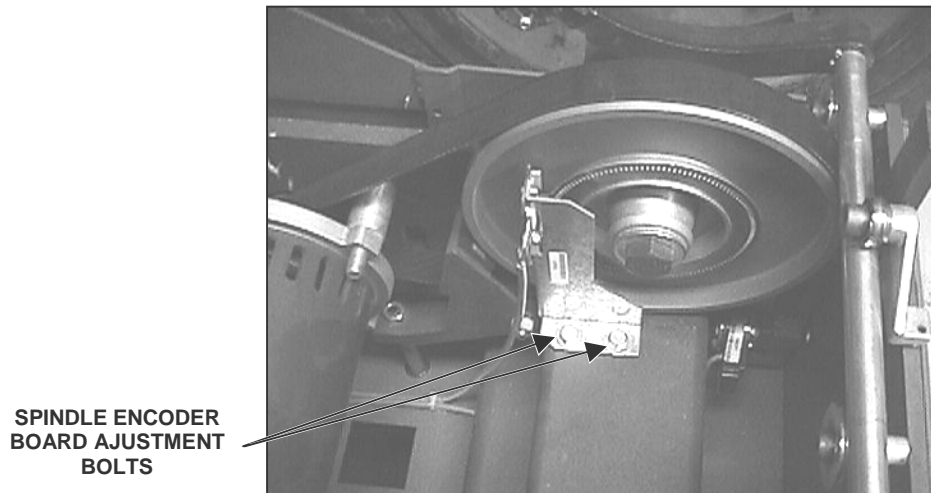

2. Loosen the adjustment bolts and adjust the spindle encoder board so that it is centered and has a 1/32 inch to 1/16 inch gap at the back of the board.

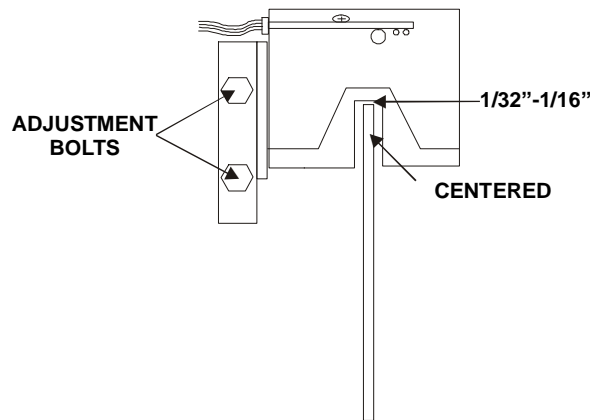

3. Tighten the adjustment bolts, being careful to keep the board in position until bolts are tight.
4. Verify proper operation by performing a balance spin and a runout spin. If spin encoder error cannot be resolved by above procedure, refer to "Rotary Encoders," page 3-4 for on-screen diagnostics procedure.

Screen Error:

Adjustment:

Multiple or erratic home pulse

Move encoder board away from the brass encoder ring.

Home pulse not found

Move encoder board toward the brass encoder ring.

NOTE:

It may be necessary to make the initial bracket position compensate for bracket flex when tightening the bolts.

## GSP Board, 45-715-3

The GSP board controls operation of the entire GSP9700 Series Vibration Control System. Static sensitive components on the GSP board can easily be damaged if anti-static precautions are not observed while you are working inside the console. The GSP board is a printed circuit board that interfaces with the interconnect board, printer port, program cartridge, power supply, and CRT port. A 25 watt power supply in the console provides +5v and  $\pm 12$ v inputs. The +12v drives the air valves and beeper, while the  $\pm 12$  feed the  $\pm 5$ v analog voltage regulators on the GSP board. The  $\pm 5$ v analog powers the data acquisition circuits on the GSP board. To verify a voltage, use the power supply test pads on the GSP board.

### TEST PADS

+12  
 +5A  
 +5 (GENERATED ON GSP BOARD)  
 -12  
 -5 (-5 ANALOG, GENERATED ON GSP BOARD)  
 GND (GROUND)

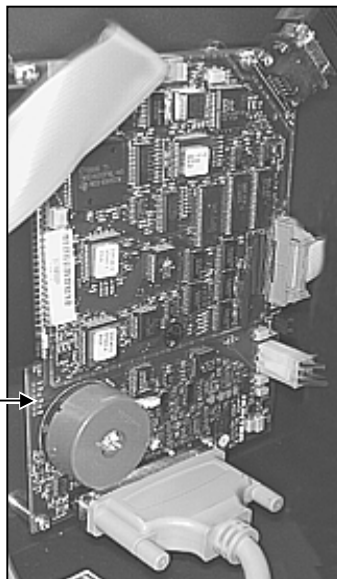

The GSP board is not field serviceable. Exchange all failed boards.

### Removal

1. Disconnect the power cord from the power source.
2. Disconnect all cables from the GSP board.
3. Remove the program cartridge from the GSP board.
4. On GSP9712 models, it will also be necessary to remove the knob interconnect board. Refer to "Knob Interconnect Board," page 2-28.
5. Remove the four screws that attach the GSP board to the console.

### Installation

1. Attach the GSP board to the console with the four previously removed screws.
2. Install the program cartridge and cables using the chart as a reference guide.

CONNECTOR	LOCATION
Interconnect Cable	J1
Knob(s) Board Cable	J2
Program Cartridge	J3
CRT Connect Cable	J4
Power Supply Cable	J5
Printer Cable	J6

3. Reconnect the power cord to the power source.
4. Calibrate the GSP9700.

## CRT, 227-80-2 (GSP9702 Only)

**⚠ CAUTION:** Care must be used when handling the assembly to avoid damaging the CRT or circuit boards.

The color CRT requires AC line voltage to operate. A cable connected from the back of the balancer console to the CRT supplies this power.

The CRT assembly is field serviceable only for setting brightness, contrast, size, and centering. Exchange any failed CRT.

### Remove Console from Cabinet as follows:

1. Turn console power switch off.
2. Disconnect AC power cord from power source.
3. Disconnect air supply hose from air supply.
4. Using a 5/32 inch Allen head wrench, remove two bolts that secure the weight anvil to the weight tray.

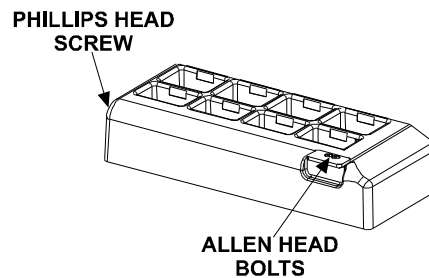

5. Remove the Phillips head screw from the front left corner of the weight tray.
6. Extend the inner Dataset® arm out past the spindle shaft.
7. Rotate the arm so that it catches on the spindle shaft to prevent the arm from returning to the "home" position.

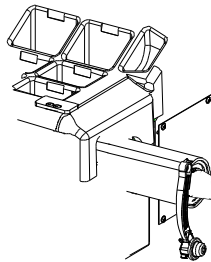

8. Lift the weight tray straight up and off the base.
9. Remove two screws securing the access cover to the bottom of the console.

10. Disconnect the 37-pin Dsub data cable and black power cord from inside the console, making note of their locations.

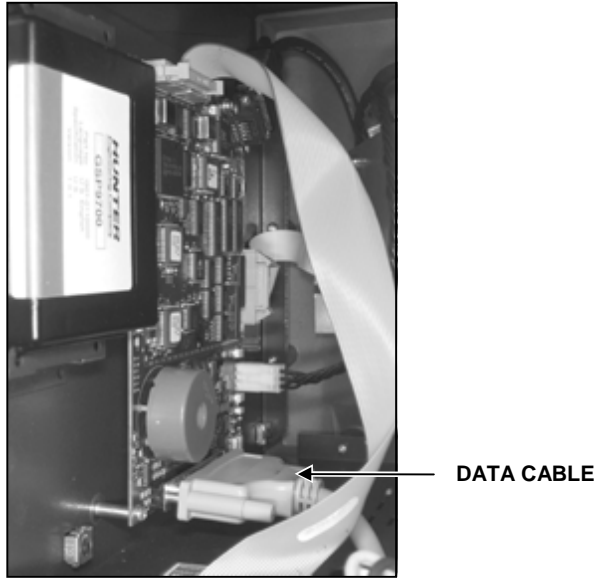

11. Remove strain relief grommets from power cord where it exits the console and where it passes through the CRT support riser.

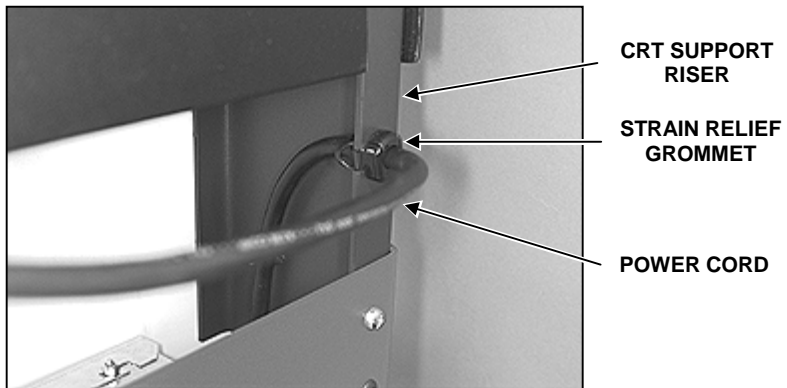
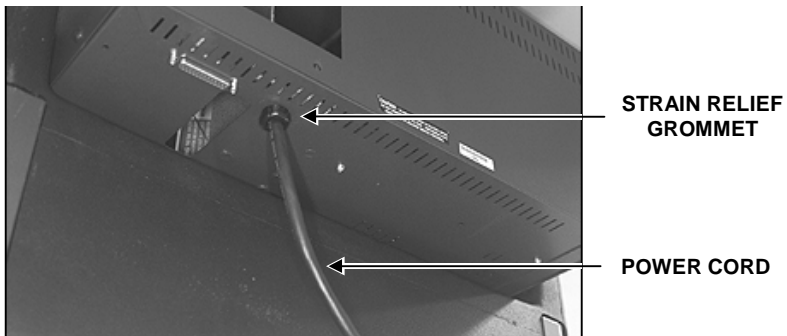

12. Remove data cable and power cord from CRT support risers.

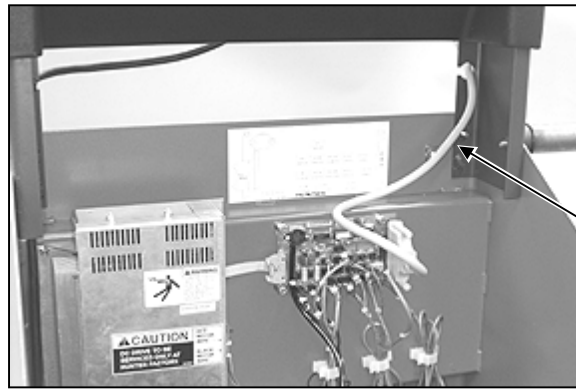

37-PIN DSUB  
DATA CABLE

13. Using a 1/4 inch drive ratchet, 12 inch extension, and 5/32 inch hex head male socket, remove two SBHCS (Allen head) screws, 75-481-2, from each side of the console.

**NOTE:** Adhesive spray may be used on the bolt to hold the bolt to the wrench during installation. Be careful to not drop any bolts.

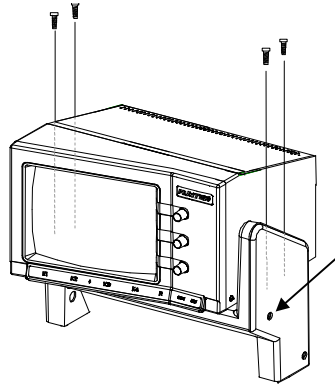

**IF THERE IS A SHOCK MOUNT KIT INSTALLED, REMOVE THE UPPER SCREW ON EACH SIDE, AS WELL AS THE COUNTERWEIGHT TUBE BOLT**

14. Lift console off console support and position face down on a padded work surface.

**NOTE:** Use bubble wrap or soft cloth work surface to prevent damage to the CRT.

#### **Reinstall Console onto Cabinet as follows:**

**NOTE:** If installing CRT Shock Mounting Kit 20-1447-1, proceed with instructions in Form 4432T, before reinstalling the console.

1. Reinstall top cover onto console and secure with screws previously removed.
2. Position console onto console support.
3. Secure console to GSP9702.
4. Route the 37-pin Dsub data cable and black power cord into console.
5. Reconnect data cable and black power cord.

6. Reinstall access cover to back of console and secure with two screws previously removed.
7. Reinstall weight tray and secure with bolts previously removed.
8. Reconnect air supply hose to air supply.
9. Reconnect AC power cord to power source.
10. Turn on console power switch.
11. Verify proper operation.

**NOTE:** When a Kristel brand monitor is powered up, the monitor screen will become brighter than normal, and you will see the raster lines. Within a few seconds this condition will stop. This is normal and is not an indication of a malfunctioning monitor.

## Adjustment

**NOTE:** With the CRT cover, 69-828-1, in place, degauss using a degaussing coil before making any adjustments.

1. Remove two screws, 75-312-2, securing the access panel to the rear of the CRT assembly, 30-330-1. Lift up or remove the access panel.
2. Locate adjustment controls inside of the CRT assembly.

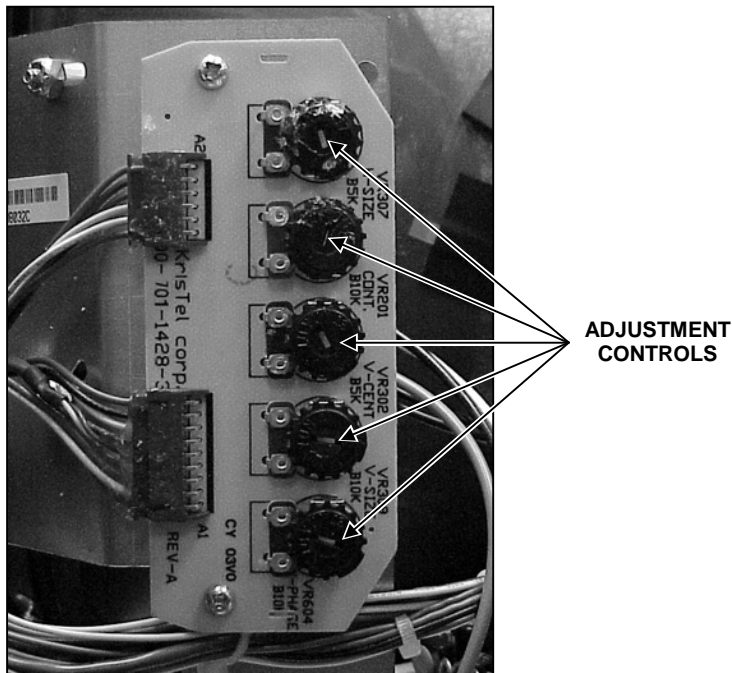

3. Adjust the display as needed, using the controls.
4. Replace the access panel or return it to the installed position.
5. Check the CRT for accurate video display.
6. Secure CRT access panel with previously removed screws.

## CRT Removal (GSP9702 Only)

1. Disconnect the power cord from the power source.
2. Remove the console from the GSP9702. Refer to "Remove Console from Cabinet," page 2-35.
3. Remove the seven screws, two on each side of the console and three on the back, securing the console cover to the console. Remove the console cover.

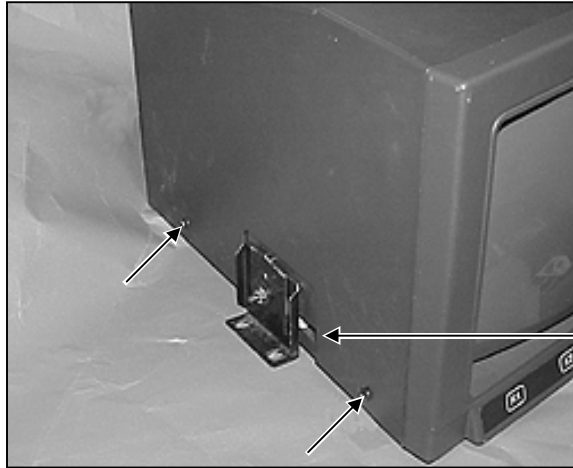

**NOTE: THIS BRACKET WILL ONLY BE ON EARLY PRODUCTION UNITS THAT HAVE NOT HAD THE SHOCK MOUNTING KIT INSTALLED.**

4. Place the CRT on a workbench and position bubble wrap in front of the CRT. Turn the assembly so the CRT tube is facing down on the bubble wrap.
5. Disconnect the harness connector that attaches the power supply board to the CRT board.

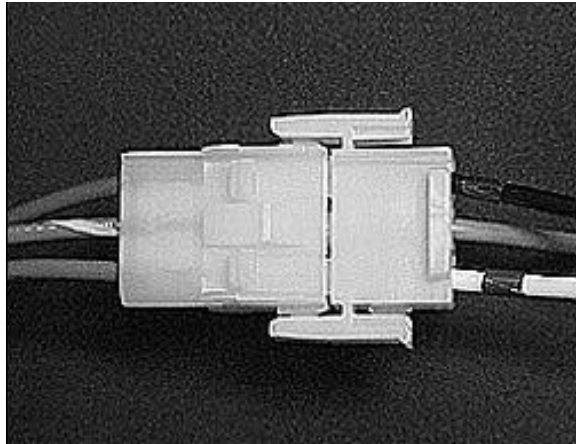

6. Disconnect the video harness from the GSP Board.

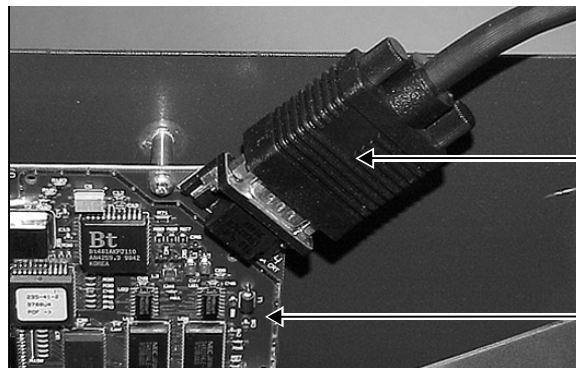

**VIDEO HARNESS**

**GSP BOARD**

7. Remove the two screws that hold the CRT board to the CRT mounting plate on the bottom of the console.



**CRT BOARD SCREWS**

8. Remove the two Phillips head screws from the CRT potentiometer adjustment board.

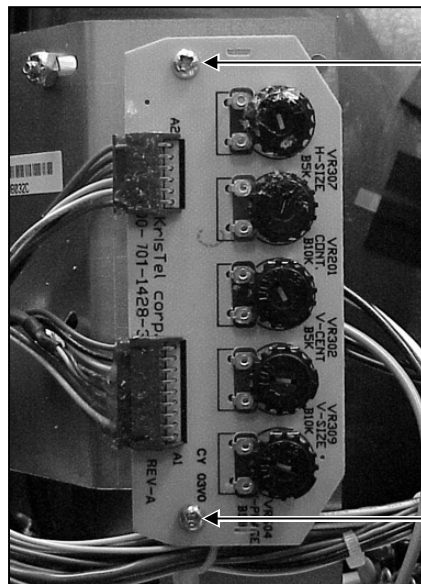

**PHILLIPS HEAD SCREW**

**PHILLIPS HEAD SCREW**

9. Remove the four bolts from the corners of the CRT.

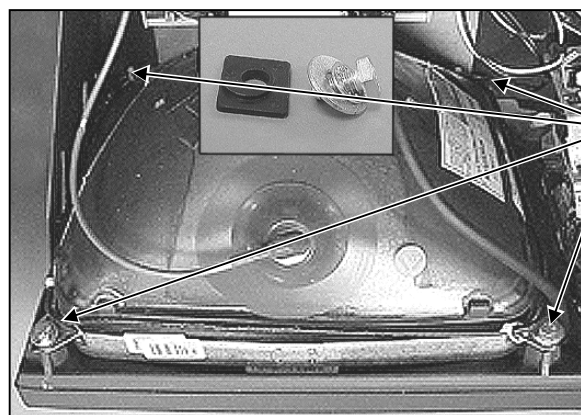

**BOLT**

10. Remove the CRT assembly from the console.



### **Installation (GSP9702 Only)**

1. Place the CRT assembly into the console. Place the four bolts in the corners of the CRT and tighten.
2. Place the two screws that hold the CRT board to the console into the CRT mounting plate.
3. Place the two Phillips head screws in the new potentiometer adjustment board for the CRT.
4. Connect the harness connector that attaches the power supply board to the CRT board.
5. Connect the video harness to the GSP Board.
6. Place the console cover on the console and align the screw holes. Replace the seven screws, two on each side of the console and three on the back, to secure the console cover to the console.
7. Place the console of the GSP9702 onto the CRT pivot cover.
8. Reconnect the power cord to the power source.

## Installing the Kristel Monitor Upgrade, Kit 20-1448-1 (GSP9702 Only)

1. Remove console from cabinet. Refer to "Remove Console from Cabinet," page 2-35.



DATA CABLE

2. Position console face down on a padded work surface.

**NOTE:** Use bubble wrap or soft cloth work surface to prevent damage to the CRT.

3. Remove the four screws (two on each side of the console) and the three screws across the back, that secure the console cover to the console.

**NOTE:** Some early production models have only four screws (two on each side).

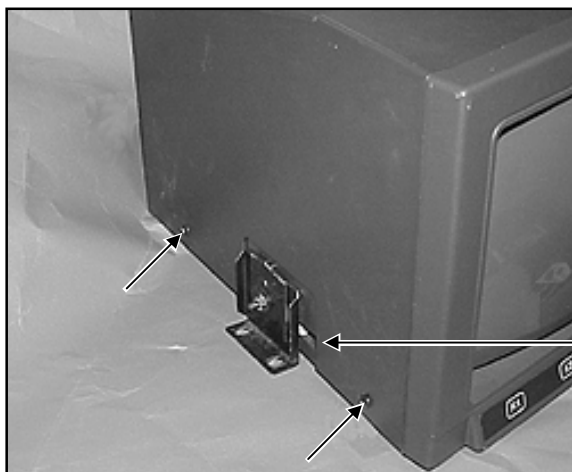

**NOTE:** THIS BRACKET WILL ONLY BE ON EARLY PRODUCTION UNITS THAT HAVE NOT HAD THE SHOCK MOUNTING KIT INSTALLED.

4. Remove the CRT console cover.

5. Remove the two screws that secure the CRT board to the bottom of the console. To remove these screws, it will be necessary to hold the nut on the CRT board with a 5/16 inch socket while turning the screw. When the screw and nut are disassembled, remove the nut, and take hold of the metal spacer before removing the screw from the bottom of the console.

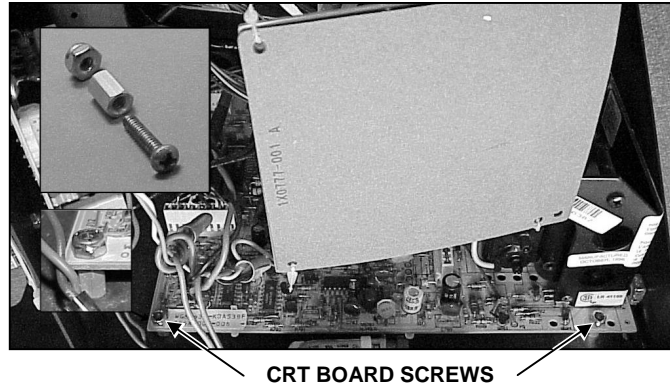

6. Remove four screws securing potentiometer adjustment board.
7. Remove four screws securing CRT.

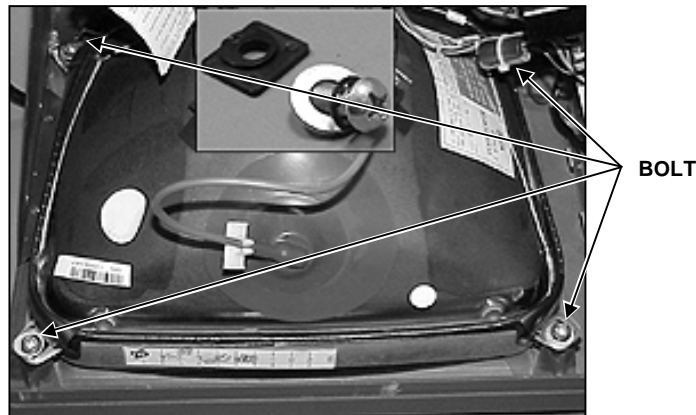

8. Remove CRT, CRT board, and potentiometer adjustment board as one assembly.
9. Enlarge existing CRT board mounting hole (located at right rear corner while facing toward front) to 9/32 inch.

**NOTE:** Before drilling, place shop towels, or other protective covering over the internal components of the console to avoid damage to the circuit boards.

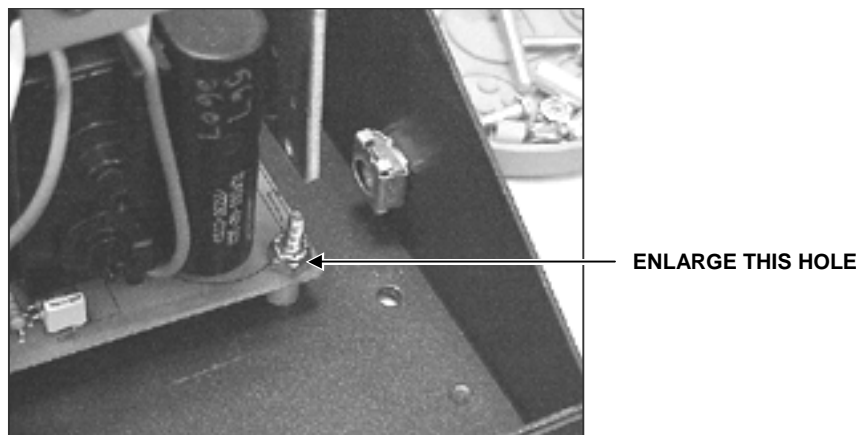

10. Secure CRT to console with four screws previously removed.
11. Install new 5/16 inch spacer, 46-328-2, between console and CRT board at hole that was previously enlarged.
12. Secure CRT board to console with screw previously removed, flat washer, 77-17-2, and grip nut previously removed.
13. Position original spacer between CRT board and console at left-side mounting hole. Secure CRT board to console with screw and grip nut previously removed.
14. Install Kristel monitor plate assembly, 51-1699-1, to the location from which the potentiometer adjustment board was previously removed.
15. Position two receiver board spacers, 46-346-2, between Kristel monitor plate assembly and potentiometer adjustment board. Secure potentiometer adjustment board to Kristel monitor plate assembly with two screws and grip nuts previously removed.

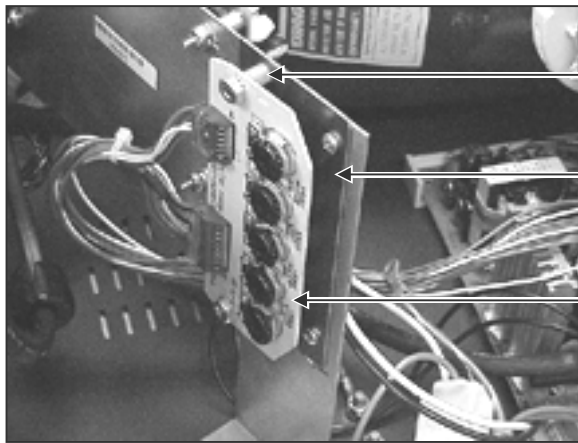

RECEIVER BOARD  
SPACER,  
46-346-2

KRISTEL MONITOR  
PLATE ASSEMBLY,  
51-1699-1

POTENTIOMETER  
ADJUSTMENT  
BOARD

## Installing the CRT Shock Mounting Kit, 20-1447-1 (GSP9702 Only)

1. Remove console from cabinet. Refer to "Remove Console from Cabinet," page 2-35.
2. Remove 1/4 inch grip nut from each pivot stud on console. Retain for use during reinstallation. Remove and discard washers and brackets.
3. Remove two THSMS (Phillips head) screws, 75-401-2, securing CRT pivot cover to each of the two CRT support risers.
4. Remove the CRT pivot cover from the support risers.
5. Using a 5/32 inch Allen wrench, remove two SBHCS (Allen head) screws, 75-481-2, at the rear of the base and one SBHCS (Allen head) screw, 75-481-2, on the side of the base, that secure each of the CRT support risers.

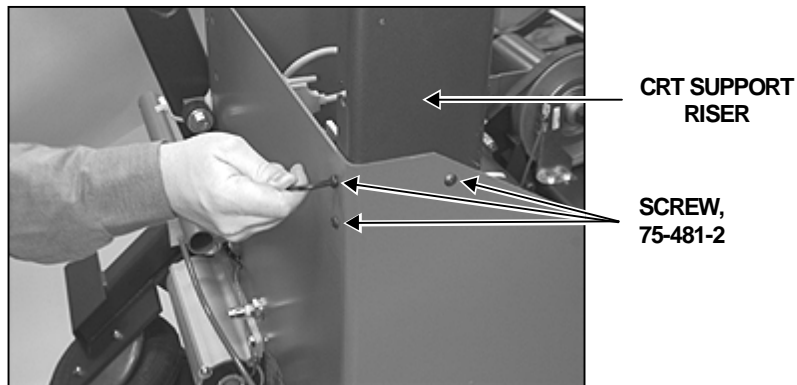

6. Install one shock mounting block, 121-183-2, on each of the two pivot studs on the console. Position the shock mounting block so that the long side of the block faces the rear of the console.
7. Install one CRT support bracket riser, 14-887-002, on each of the two pivot studs on the console. Secure with grip nuts previously removed.

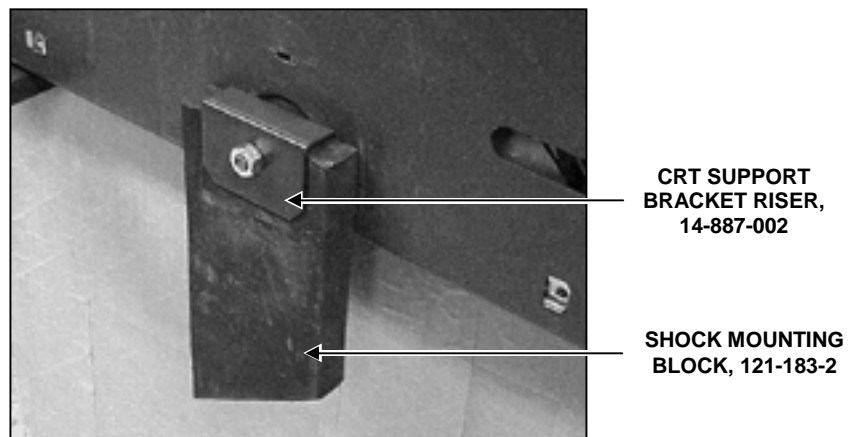

- Remove the four screws (two on each side of the console) and the three screws across the back, that secure the console cover to the console.

**NOTE:** Some early production models have only four screws.

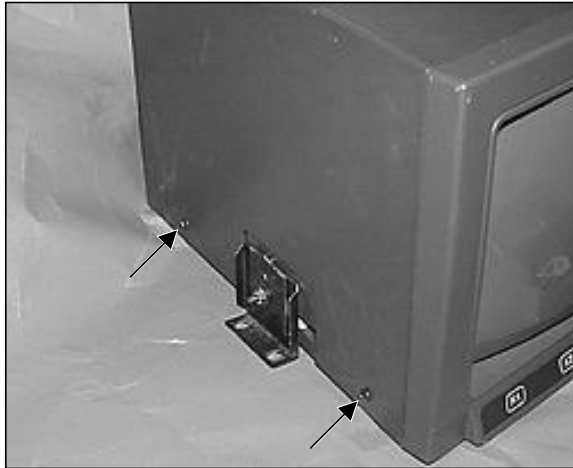

- Remove top cover from console.
- Position CRT counterweight bar, 57-621-002, on bottom of console, flush with the back of the console and protruding 1 5/8 inch to the right, as looking at the back of the console.

**NOTE:** Mounting holes in the CRT counterweight bar should be toward the back of the console.  
  
Hole at the end of the counterweight bar should be on the protruding end.

- Clamp CRT counterweight bar, 57-621-002, to console with two C-clamps.

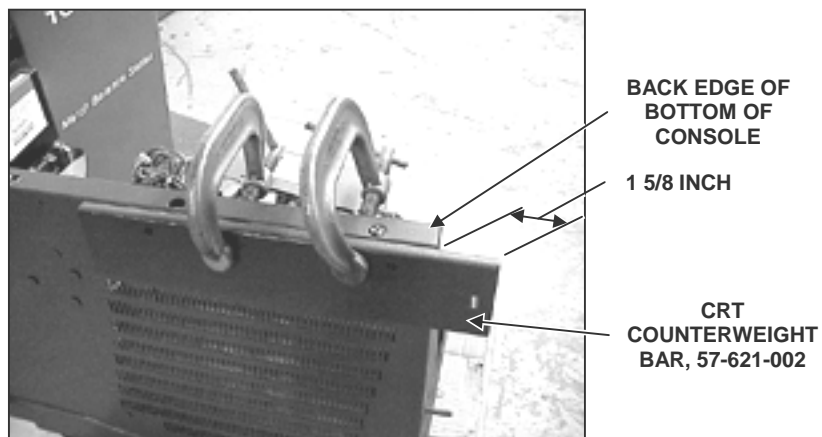

**NOTE:** Before drilling, place shop towels, or other protective covering over the internal components of the console to avoid damage to the circuit boards.

- Using CRT counterweight bar as a template, drill two 9/32 inch holes in the bottom of the console.

13. Remove C-clamps.
14. Place two 1/4 inch flat washers, 77-67-2, between the CRT counterweight bar and the console. Secure the CRT counterweight bar to the console with two 1/4 inch screws, 75-22-2, and two 1/4 inch nuts, 76-85-2.
15. Secure each CRT support riser assembly, 119-35-1-002, and 119-36-1-002, to the cabinet base with three screws previously removed.

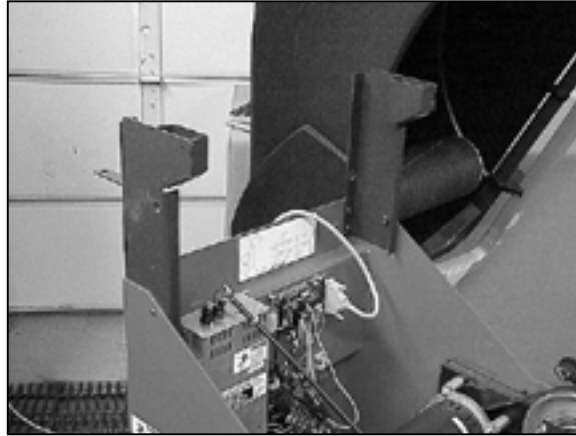

16. Secure rear CRT shock support bracket, 14-888-002, to the right-hand (as facing the rear of the machine) CRT support riser assembly with two 1/4-20 x 0.50 SBHCS, 75-481-2.

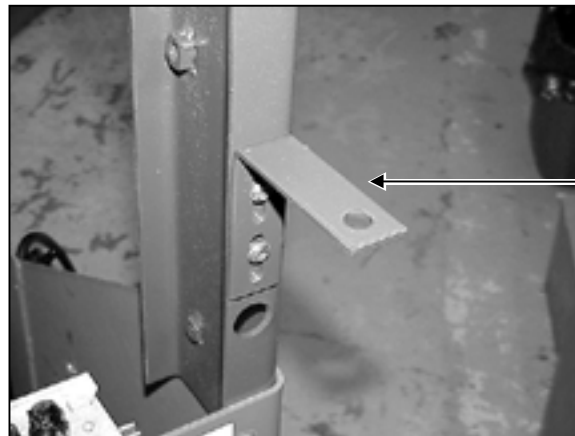

**REAR CRT SHOCK  
SUPPORT BRACKET,  
14-888-2**

17. Place the CRT pivot cover, 69-826-2, over the risers.

18. Secure the CRT pivot cover with one THSMS (Phillips head) screw, 75-401-2, in the lower screw holes on each side of the cover.

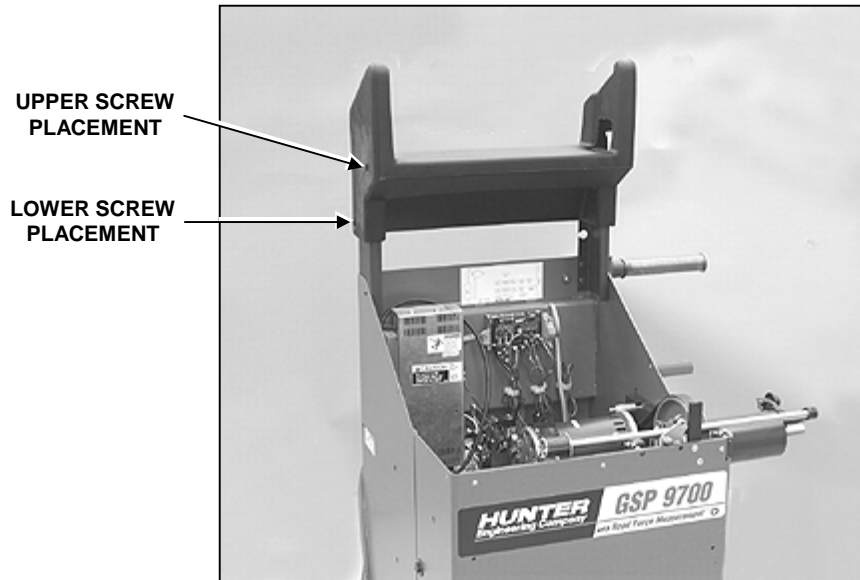

19. Secure rubber counterweight tube, 16-648-2, to rear CRT shock support bracket with 3/8 inch x 1.00 ZP lag screw, 74-286-2.

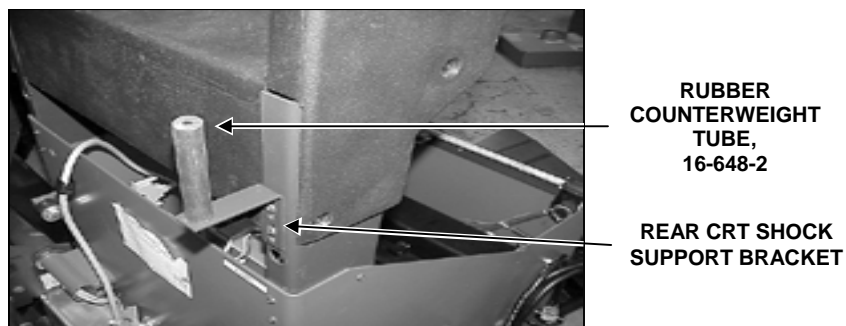

20. Reinstall CRT console cover. Refer to "Reinstall Console in Cabinet," page 2-37. Secure to rubber counterweight tube with 3/8 inch x 1.50 ZP lag screw, 74-405-2.

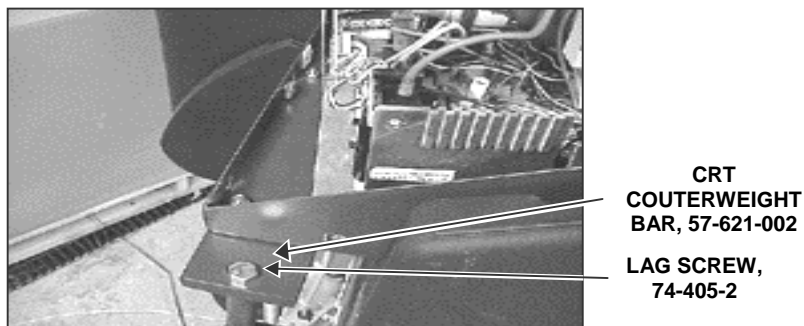

21. Secure the CRT pivot cover with remaining THSMS (Phillips head) screws, 75-401-2, in the upper screw holes on each side of the cover.



---

## CRT, 227-74-2 (GSP9712 Only)

 **CAUTION:** Care must be used when handling the assembly to avoid damaging the CRT.

The color CRT requires AC line voltage to operate. A cable connected from the back of the balancer console to the CRT supplies this power.

The CRT assembly is field serviceable only for setting brightness, contrast, size, and centering. Exchange any failed CRT.

### **Remove Console from Cabinet as follows:**

1. Turn console power switch off.
2. Disconnect AC power cord from power source.
3. Disconnect air supply hose from air supply.
4. Disconnect the CRT power cable from the CRT. Disconnect the gender changer cable from the console.
5. Disconnect the CRT data cable from the console.
6. Lift the CRT from the CRT plate assembly, 51-1887-002.

### **Reinstall Console in Cabinet as follows:**

1. Press two pieces of Velcro fastener loop, 28-89-2, onto two pieces of Velcro fastener hook, 28-90-2.

**NOTE:** Aligning each half of the Velcro together and then fastening it to the CRT pan helps ensure proper alignment of the Velcro.

2. Peel the backing off of one side of the Velcro and press into place on one of the raised pads of the CRT plate assembly. Peel the backing off of one side of the remaining Velcro and press into place on the remaining raised pad of the CRT plate assembly.
3. Peel the backing from the Velcro and then position the CRT in place. Apply firm downward pressure to the top of the CRT to secure the CRT to the Velcro.

4. Connect the CRT data cable to the console.

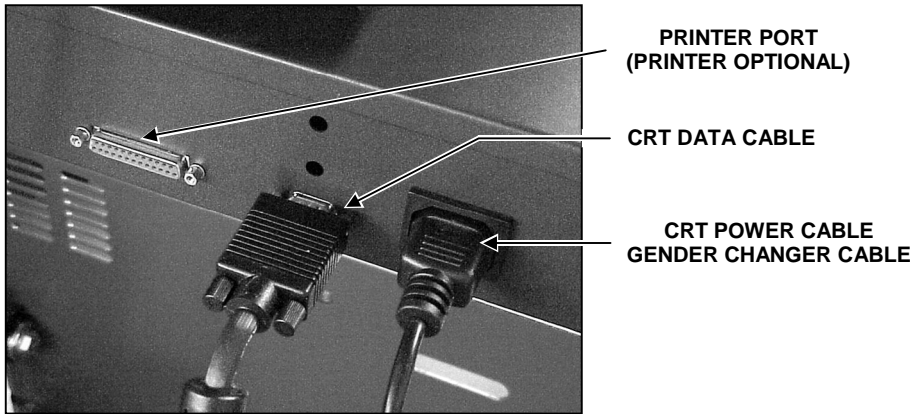

5. Connect the CRT power cable to the supplied gender changer cable. Connect the CRT power cable to the CRT. Connect the gender changer cable to the console.
6. Bundle the CRT power cable and CRT data cable and wire tie to the back of the console.

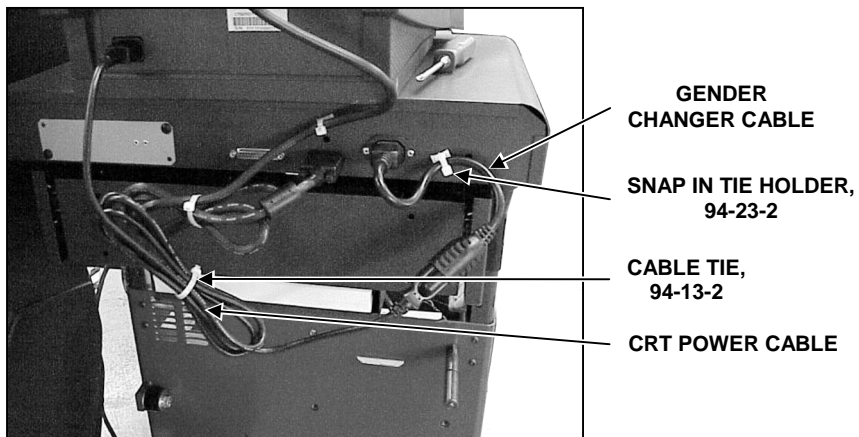

---

## Console Support Assembly (GSP9712)

### Removal

1. Remove weight tray.
2. Remove four screws securing riser cover to left riser. Repeat for right side riser.

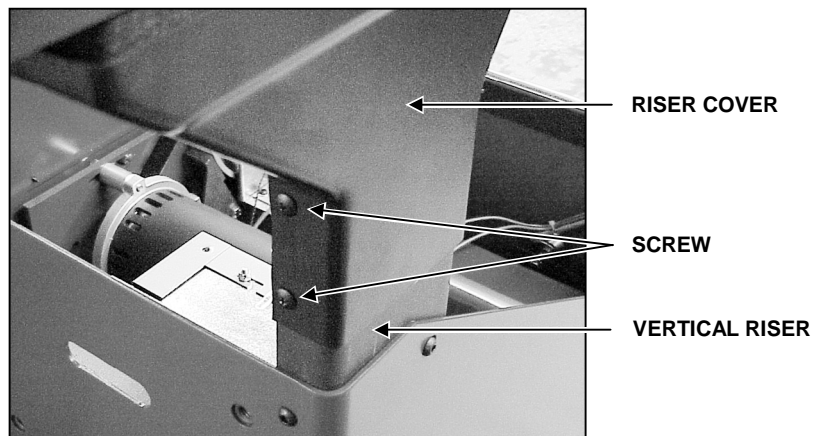

3. Disconnect the CRT data cable from the console.

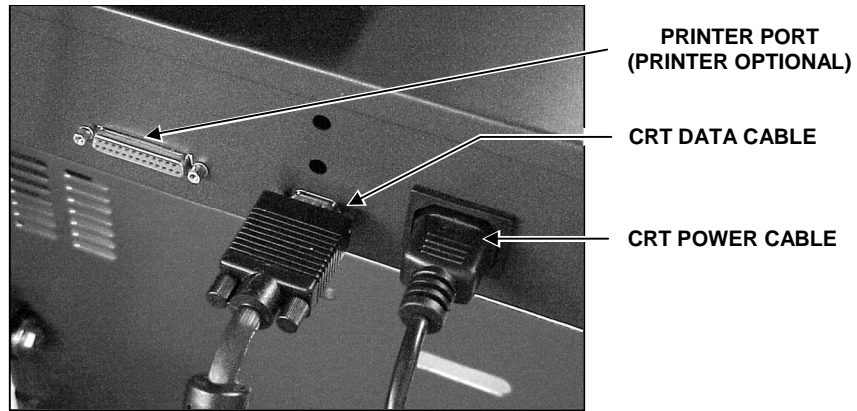

4. If installed, turn off and unplug the printer. *Refer to "Printer Removal and Installation," page 2-58.*
5. Disconnect the CRT power cable from the CRT and the console.
6. Lift the CRT from the CRT pan and set aside.
7. Remove the top cover from the CRT support console by removing four #10 Truss head screws (two from each side).
8. Disconnect the data cable from the interconnect board. Remove the data cable from the right side riser.

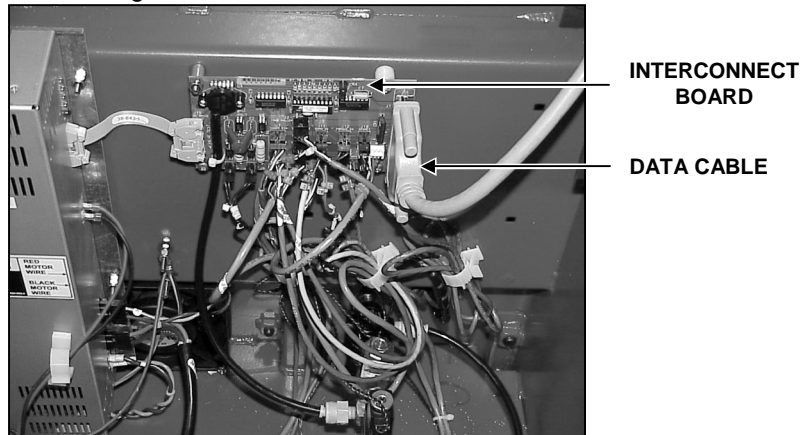

9. Disconnect the ground wire from the grounding stud located on the inside back of the base assembly. Unplug the two wires from the power supply.

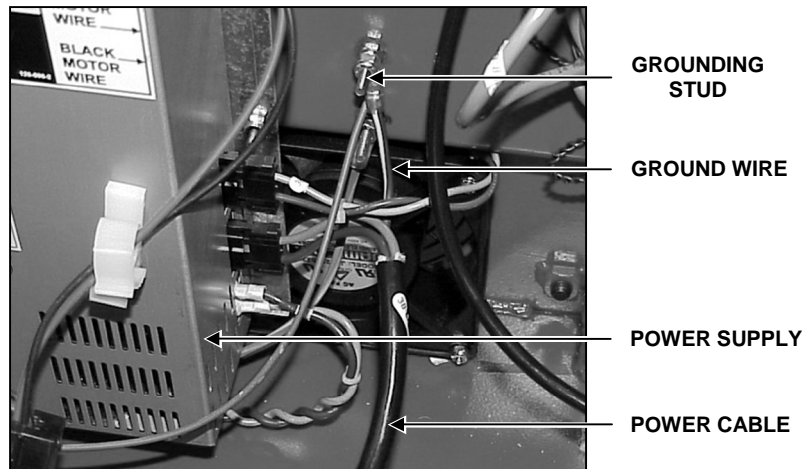

10. Remove the black power cable from the left side riser.

11. Remove the lower nut on the "L" shaped 1/4-20 rod. Repeat for the other vertical riser.

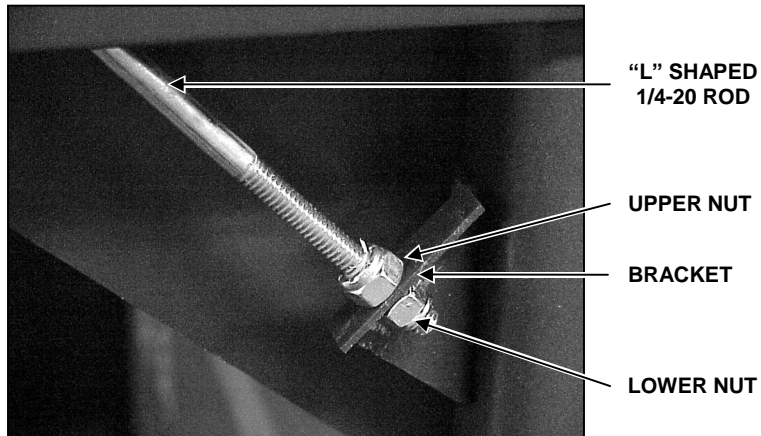

12. Remove the "L" shaped 1/4-20 rod from the bracket on the vertical riser. Repeat for the other vertical riser.

13. Remove the Nylock nuts from the two small studs and the attaching stud of the vertical riser. Remove the shock mount and the plastic bushing. Repeat for the other vertical riser.

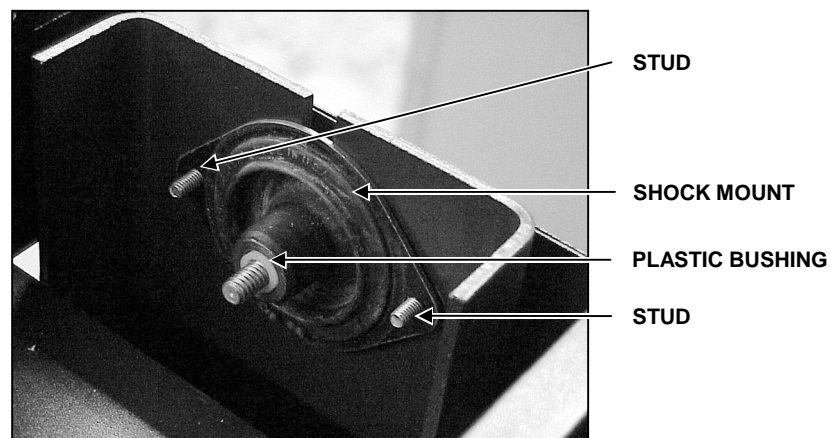
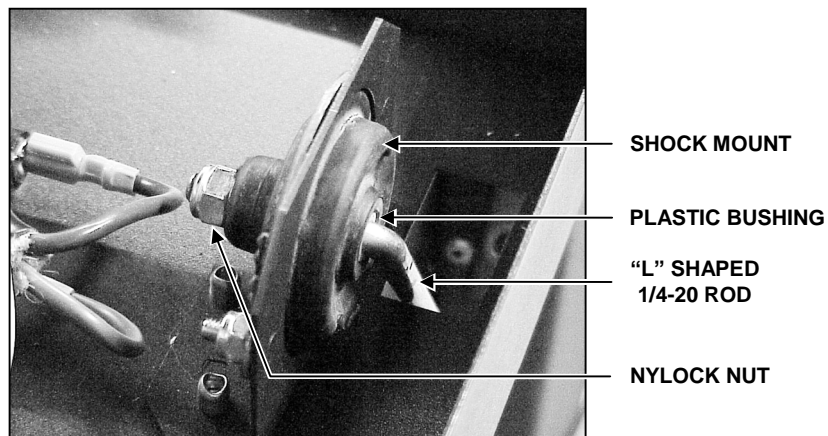

14. Lift the CRT support console from the vertical risers. The 1/4-20 attaching stud of the CRT support console should slide through the slot on the top of the vertical risers.

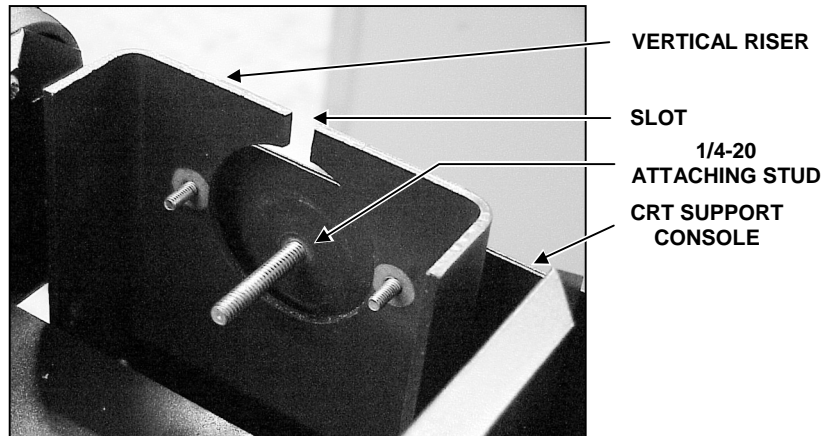

15. Remove three 1/4-20 bolts securing one vertical riser of the CRT support to the base assembly. Repeat for the other vertical riser.

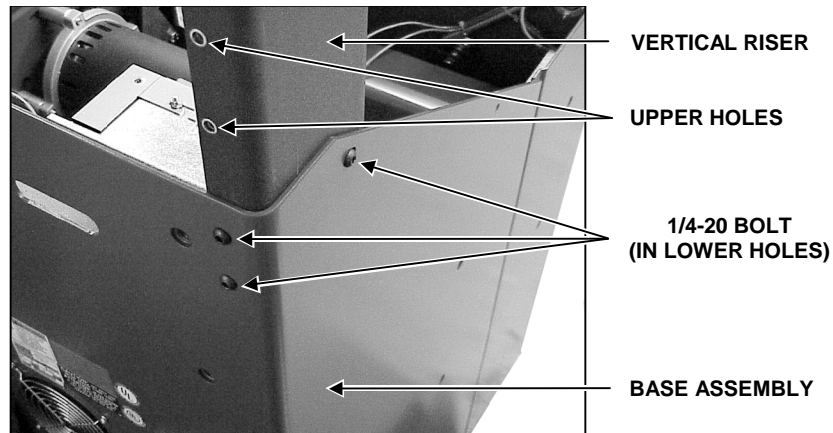

## Installation

**NOTE:** If installing the optional printer, refer to "Installation Instructions for GSP9712 Vibration Control System Printer Kit 20-1605-1," Form 4978T. The printer tray assembly may be installed onto the CRT support before or after installing the CRT support onto the base assembly.

**NOTE:** The CRT support assembly has two positions. If **not** installing the optional printer drawer, mount the vertical risers in the lowest position (upper holes). To use the optional printer drawer, mount the vertical risers in the highest position (lower holes). Refer to "Installation Instructions for GSP9712 Vibration Control System Printer Kit 20-1605-1," Form 4978T.

1. Secure one vertical riser of the CRT support to the base assembly with three 1/4-20 bolts. Two of the bolts thread into the rear of the base assembly and the third threads into the side. Repeat the procedure for the other vertical riser.

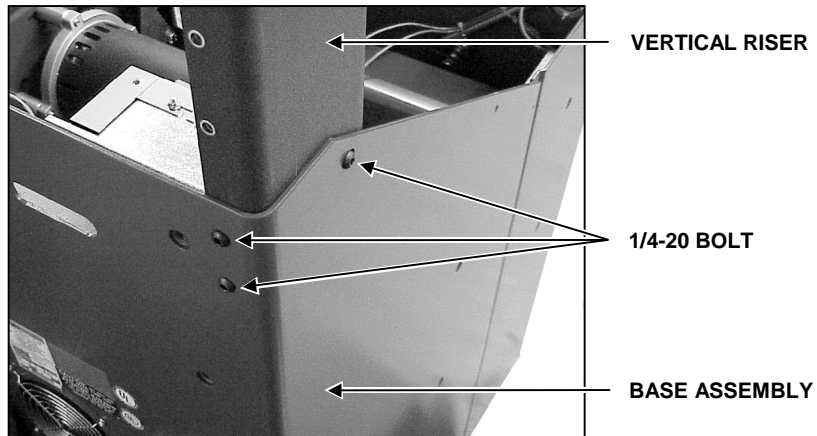

2. Remove the top cover from the CRT support console by removing four #10 Truss head screws (two from each side).
3. Slide the CRT support console down over the vertical risers. The 1/4-20 attaching stud of the CRT support console should slide into the slot on the top of the risers.

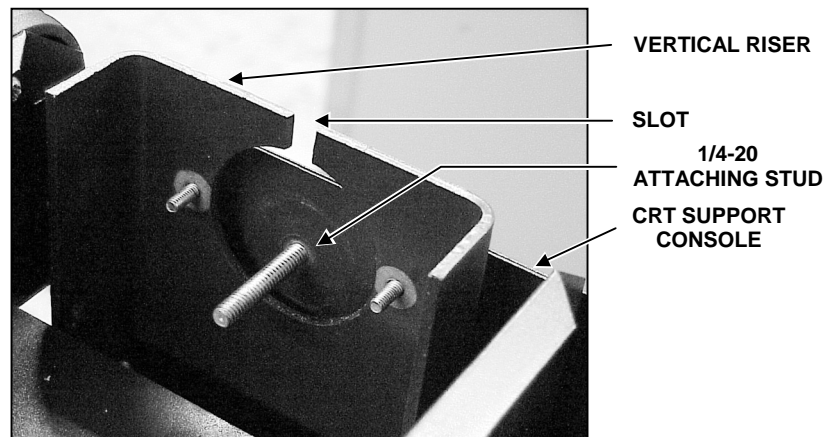

4. Slide a plastic bushing, and then the shock mount over the attaching stud and onto two studs that are pressed into the vertical riser. Secure with Nylock nuts. Repeat the procedure for the other vertical riser.

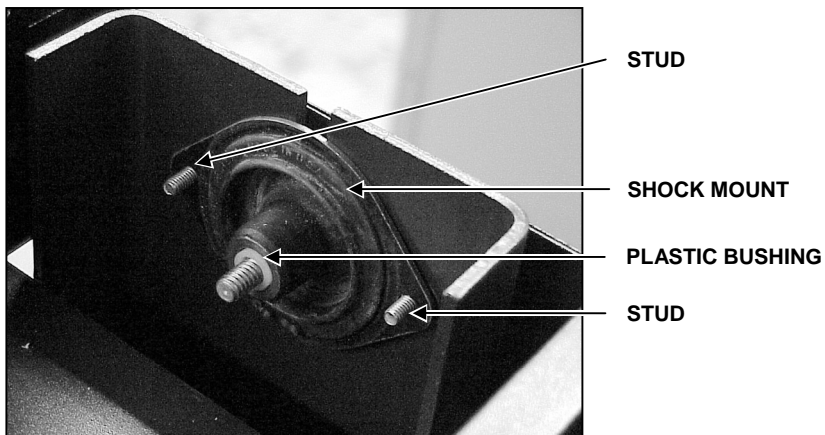

5. Position the "L" shaped 1/4-20 rod so that the long end will pass through the opening in the bottom of the CRT support console. Insert the short end of the "L" shaped 1/4-20 rod into the rear shock mount. Install a plastic bushing, and then secure with Nylock nuts. Repeat the procedure for the other rear shock mount.

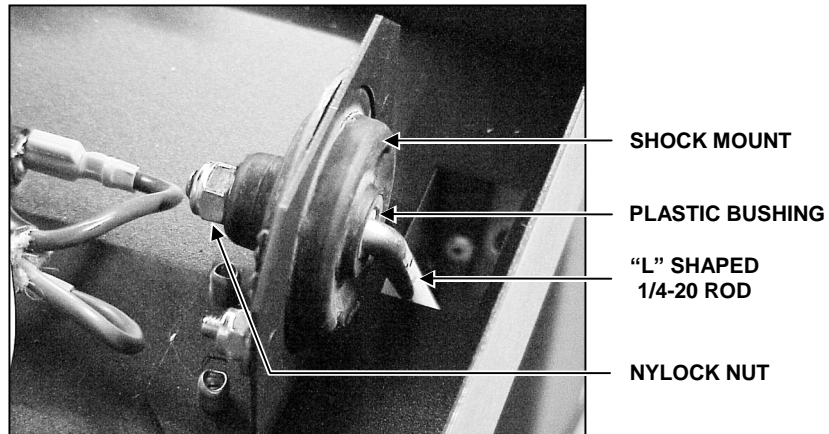

6. Remove one nut from the long end of the "L" shaped 1/4-20 rod and insert the rod into the bracket on the vertical riser. Reinstall the nut previously removed from the long end of the "L" shaped 1/4-20 rod, but do not tighten completely.

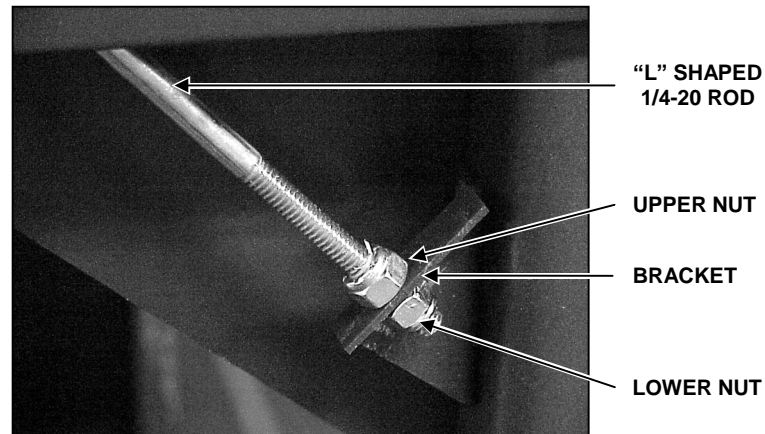

7. Level the support front to rear and side to side by loosening or tightening the upper nut on the long end of the "L" shaped 1/4-20 rod on each side.
8. When level is achieved, tighten the lower nut on the "L" shaped 1/4-20 rod.

9. Route the black power cable down through the left side riser and underneath the power supply. Plug the two wires into the power supply and connect the ground wire to the grounding stud located on the inside back of the base assembly.

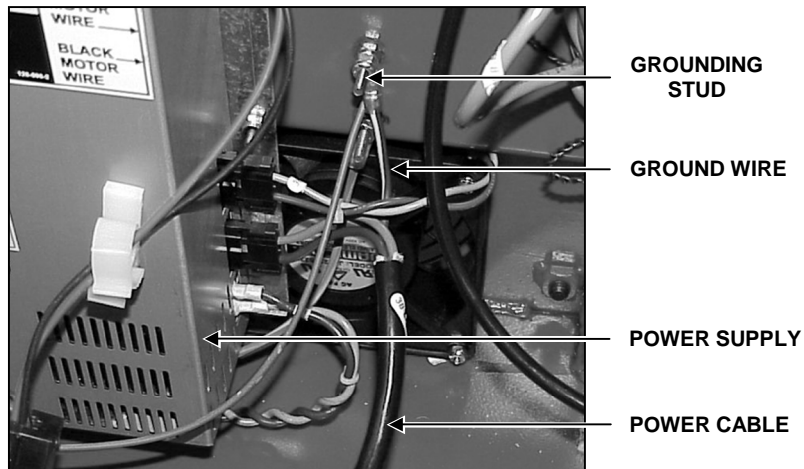

**NOTE:** Keep black cable and motor cord separated to minimize EMI noise on CRT display.

10. Route the data cable down through the right side riser. Plug the data cable into the interconnect board.

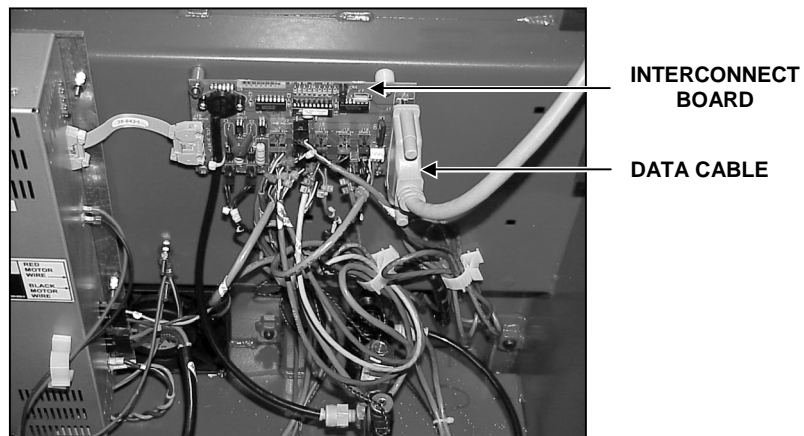

11. Install the top cover onto the CRT support console and secure with the four screws previously removed.
12. Install the CRT pan and secure with four screws.
13. Install the CRT and secure to the pan with Velcro provided.
14. Check level of support with the CRT installed. Adjust the "L" shaped 1/4-20 rod on either side as necessary.

**NOTE:** CRT's tend to be front heavy and will cause the support to lean forward toward the user.



15. Connect the CRT power cable to the CRT and the console. Connect the CRT data cable to the console.

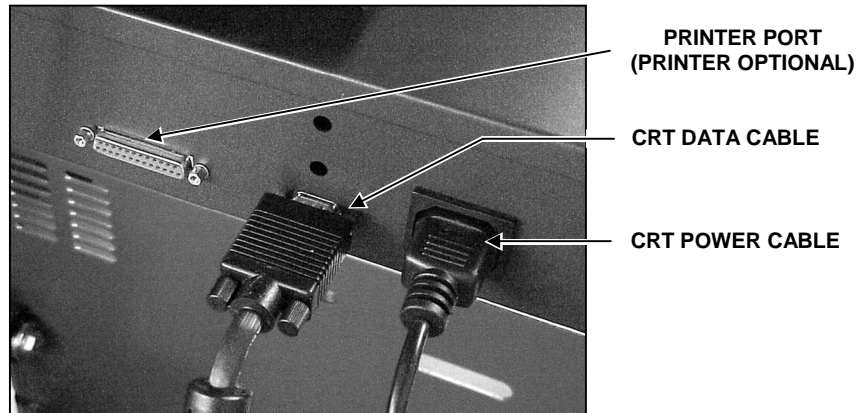

16. With monitor installed, recheck level and adjust as necessary.

17. Secure riser cover to right riser with four screws.

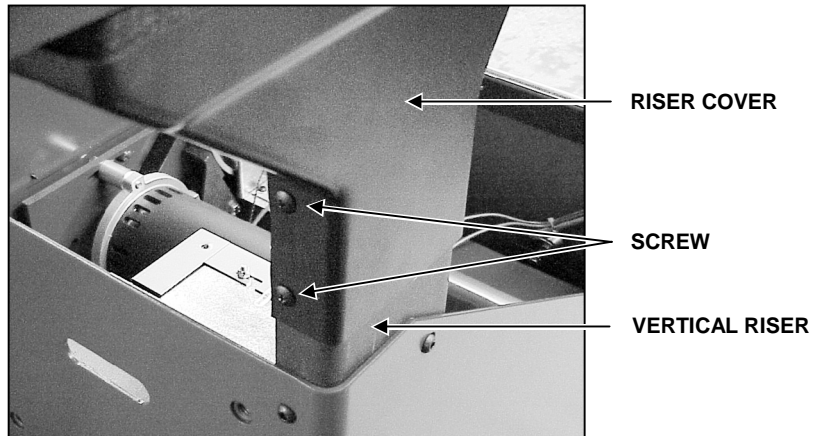

18. Secure riser cover to left riser with four screws.

---

## Printer Removal and Installation

### Removal

1. Remove the AC power cord from the AC power source.

 **CAUTION:** The AC power cord **MUST** be disconnected from the AC power source to avoid possible electrocution.

2. Disconnect printer power cord, 38-946-1, from back of printer.
3. Disconnect printer data cable, 38-657-2, from back of printer, 167-69-1.
4. Lift the printer out of the printer drawer.

### Installation

1. Remove the AC power cord from the AC power source.

 **CAUTION:** The AC power cord **MUST** be disconnected from the AC power source to avoid possible electrocution.

2. Remove printer paper from packaging and place into recess in printer drawer.
3. **Feed paper through bottom of printer** and place printer into drawer.
4. Reconnect printer data cable, 38-657-2, to back of printer, 167-69-1.
5. Reconnect printer power cord, 38-946-1, to back of printer.
6. Reconnect the AC power cord to the AC power source.

## Printer/Transformer Wiring Diagram

Refer to Form 4978T, "Installation Instructions for GSP9712 Vibration Control System Printer Kit 20-1605-1," for printer transformer installation.

The wiring diagram shown below should be used for reference only.

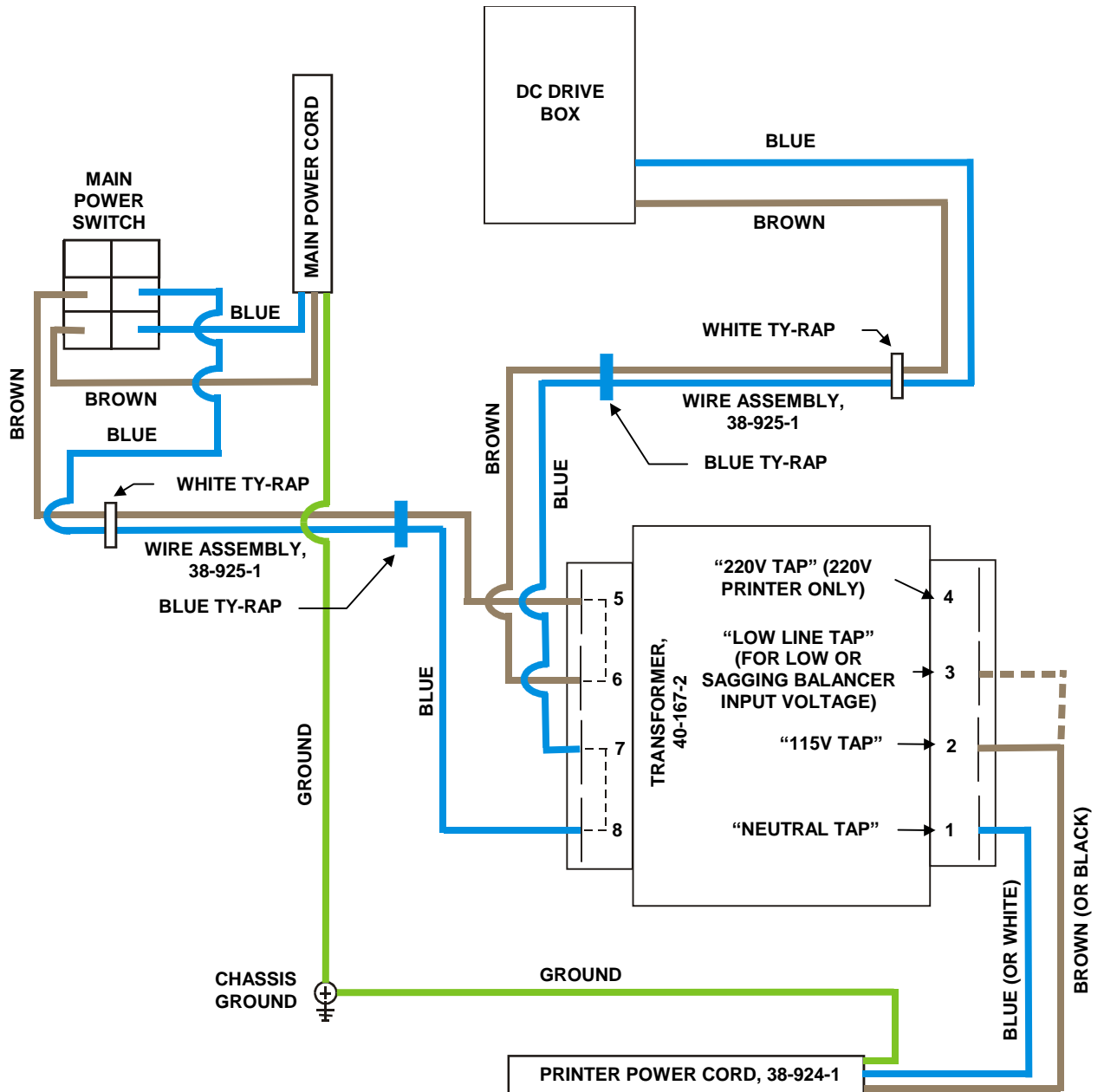

WIRING DIAGRAM

## Program Cartridge, G01-0110000-1

The GSP9700 Series Vibration Control System program cartridge provides the software to run the GSP board and balancer components.

The program cartridge is pre-programmed software that connects to J3 on the GSP Board.

The program cartridge is not field serviceable. Exchange any failed unit.

### Removal and Installation: (GSP9702)

**CAUTION:** A static wrist strap should be worn to prevent damage to static sensitive parts.

**NOTE:** Document current customer set-up preferences before cartridge removal.

1. Verify the unit power is off and the AC power cord is disconnected from the power source.
2. Remove the two Phillips screws securing the access panel to the rear of the console.
3. Raise the access panel.
4. Remove the installed program cartridge from the CRT console.
5. Insert the new program cartridge into the console. Ensure proper alignment of the cartridge guides with the console alignment guides.

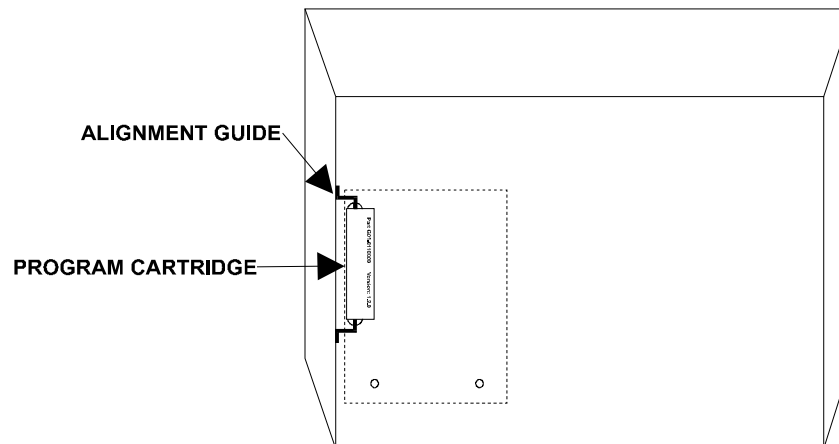

6. Reinstall the access panel and secure with the two Phillips screws previously removed.
7. Re-attach the AC power cord.
8. Calibrate the GSP9702.

**NOTE:** If the high pitched tone that is heard when electrical power is initially applied to the GSP9700 Series Vibration Control System does not stop after approximately six seconds, the program software is not installed correctly. Switch off the balancer and correct program cartridge installation.

## Removal and Installation: (GSP9712)

**CAUTION:** A static wrist strap should be worn to prevent damage to static sensitive parts.

**NOTE:** Document current customer set-up preferences before cartridge removal.

1. Verify the unit power is off and the AC power cord is disconnected from the power source.
2. Remove the two Phillips screws securing the access panel to the rear of the console.

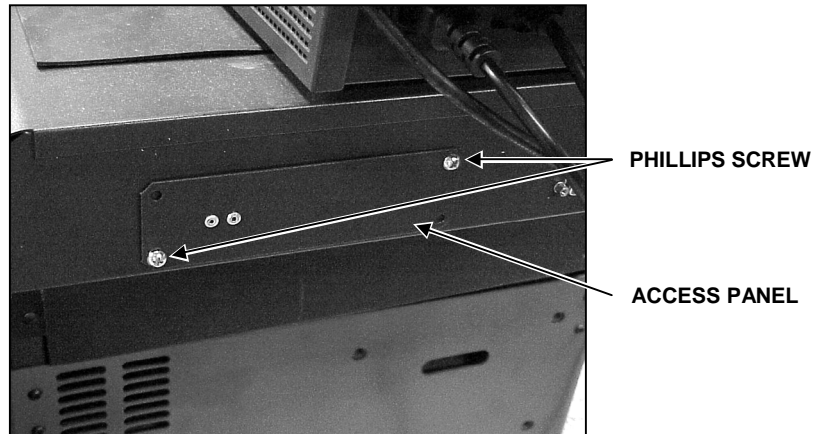

3. Remove the access panel.
4. Remove the installed program cartridge from the CRT console.
5. Insert the new program cartridge into the console. Ensure proper alignment of the cartridge guides with the console alignment guides.
6. Reinstall the access panel and secure with the two Phillips screws previously removed.
7. Re-attach the AC power cord.
8. Calibrate the GSP9712 (if instructed to do so by the new software).

**NOTE:** If the high pitched tone that is heard when electrical power is initially applied to the GSP9700 Series Vibration Control System does not stop after approximately six seconds, the program software is not installed correctly. Switch off the balancer and correct program cartridge installation.

## DC Motor Drive, 232-115-1

Replace any failed DC Motor Drive.

**⚠ DANGER:** Do NOT operate or plug in the unit unless the motor drive box is bolted to the cabinet and the cabinet is properly grounded!

Do NOT attempt to service the DC Motor Drive. This is NOT a field serviceable item and any attempt to open the box and service it may result in severe personal injury or death.

### Removal:

1. Unplug power cord from the power source.
2. Disconnect the interconnect board cable, 38-843-1, from the DC Motor Drive.
3. Disconnect the motor wires from the DC Motor Drive.
4. Disconnect the fan and upper console power supply from the DC Motor Drive.
5. Disconnect the power wires from the DC Motor Drive.

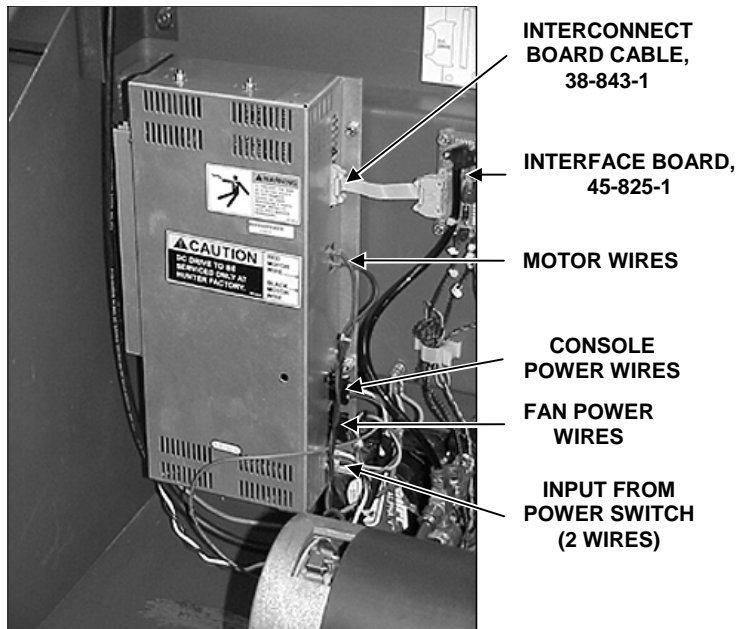

6. Remove the four nuts that secure the DC Motor Drive to the base of the GSP9700.

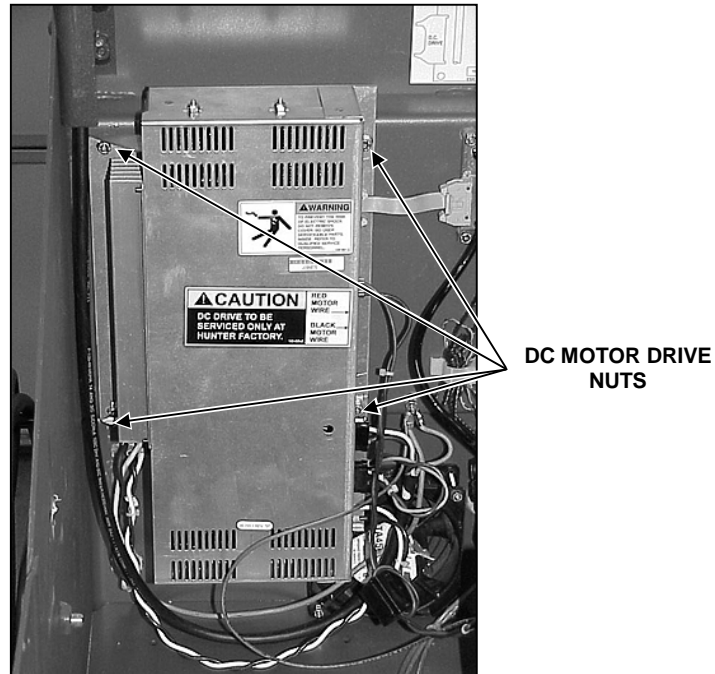

### Installation

1. Align DC Motor Drive bolt holes with bolts in base. Secure with four nuts previously removed. Tighten nuts to 25 ft-lbs.
2. Reconnect the fan and upper console power wires to the DC Motor Drive. (Locations are interchangeable.)
3. Reconnect the power wires from the switch to the DC Motor Drive.
4. Reconnect the motor wires to the DC Motor Drive.
5. Disconnect the interconnect board cable to the DC Motor Drive.
6. Plug power cord into the power source.
7. Verify proper operation of the motor by spinning with and without the load roller enabled. If a direction error occurs, the motor leads are exchanged. One motor brand will have a red and black wire coming out of it and the other will have two black wires coming out of it. When there is a red and black lead, the red lead goes on top. If there are two black leads, the one marked A2 goes to the top. Correct rotation for a load-roller spin is counterclockwise (top of tire moves toward you) and clockwise for balance-only spin.





# 3 .Service Mode Diagnostics

The GSP9700 Series Vibration Control System provides a “Service Diagnostics” mode to allow you to view and diagnose concerns with information not available from the user mode.

“Service Mode Diagnostics” can be toggled by holding down the “K2” and “K3” softkeys simultaneously, while pressing the reset button twice. The logo screen title should change to “GSP9700 Service Mode.” Select “Diagnostics” from the logo screen. As you scroll through the different diagnostic text, the illustration changes to highlight the selected testable components in yellow.

**NOTE:** If the GSP9700 title does not change to “Service Mode Diagnostics,” you may have old software. To access the “Service Mode Diagnostics,” turn the power off and back on while holding down the “K2” and “K3” softkeys simultaneously. Wait approximately six seconds for the GSP9700 to “boot up.”

---

## Force Sensors

Force sensors are tested to verify that the balancing sensors are working properly and that the balancer frame is not rubbing against the spindle housing.

Chasing weights will result from contact between the spindle and cabinet. Pay close attention to the side of the cabinet from where the spindle projects. To check for balancer frame clearance, verify that there is ample clearance to slide a business card between the black spindle housing surrounding the spindle and the balancer frame. It may be necessary to file the red balancer frame to provide ample clearance.

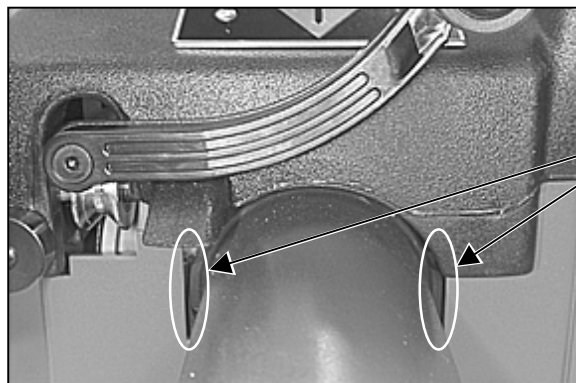

**LOOK FOR  
PROPER  
CLEARANCE IN  
THESE AREAS**

The spindle structure should only contact the cabinet at the mounting points. Stray wheel weights, nuts, bolts, etc. can wedge under the spindle structure and reduce the transfer of vibration to the transducers. An indication of this condition would be sensor output display plots that are close to equal in magnitude for the left and right sides after spinning with the calibration weight.

Repeatability concerns may be experienced if the belt tension adjusting cam bolt is rubbing on the access cover. Symptoms of force transducer problems will most likely be a complaint of chasing weights or a calibration problem/failure when attempting balancer calibration.

Select "Start" at the logo screen. Select "Diagnostics" from the logo screen.

Highlight "Force Sensors" and select "Begin Selected Test."

Sensor data is shown in counts. If a spin was previously performed in balance mode, eight revolutions of data will be shown.

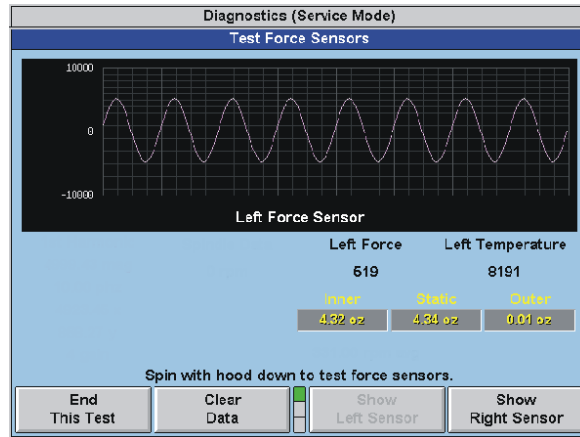

When sensor counts are numbered 8191, clipping is occurring and/or the sensor is not reading.

On this screen, there is a force value and a temperature value. The force value should be approximately  $0 \pm 100$  and will change momentarily if pressure is applied to the spindle. The temperature value is going to vary depending upon ambient temperature, but it should be approximately 700-900. Left or right sensors (transducers) can be selected from this screen.

The live temperature counts of the force sensors should rise with temperature rise.

Further testing can be done on this screen by selecting "Balance Bare Rim." For software versions before 1.2, set the balancer to the "no blind" position from the balance screen (failure to do so will result in the readout being blank).

**NOTE:** To set the balancer to the "no blind" mode, you will need to go into the regular balance screen and select "no blind." Then return to the logo screen and enter Diagnostics as you did previously.

Install a cal weight on either side, then close the hood, and press "Start." Because the right side transducer is closer to the spindle, it will have a stronger output. This is evident by viewing the graph. The plot line will be approximately 2 - 2.5 times larger on the right side vs. the left side. If either line is flat, try swapping the force sensor cables at the interconnect board.

If the problem (flat line) now moves to the opposite sensor, the sensor is suspect.

If the problem does not move to the other sensor, the problem may be the interconnect board, the interface cable, or the GSP board.

If the wheel dimensions are set to defaults (distance = 224, width = 4.9, diameter = 14.0), the cal weight will produce approximately 4.31 on inner or outer readouts (depending upon where it is installed). You should also show approximately 4.31 on the static readout. With all versions up to 1.2.1, the default settings come up when the balancer is first powered up. Version 1.3 requires you to manually set these dimensions from the balance screen.

**NOTE:**

On small tires, the load roller arm may induce noise onto the force sensor data if the GSP9700 is already into the balance portion of the spin when the arm backs into the backstop. To check for this, you must perform a loaded spin while in balance mode before using this diagnostics screen.

This will not be as common on larger tires requiring longer spin up times.

A rubber pad can be installed at the load roller backstop to absorb shock, if necessary.

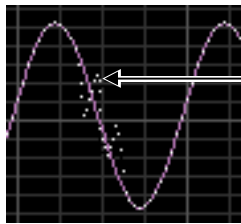

**NOISE CAUSED  
BY LOAD ROLLER  
ARM HITTING  
BACKSTOP**

For transducer drift testing, refer to “Balance/Force Non-Repeatability Flowchart,” page 4-17.

## Rotary Encoders

The rotary encoder test screen can take readings beginning from a stop or initially turning. The top wave line shows the home pulse of the spindle encoder (not used when viewing knob encoder data). The middle line and the bottom line should have a unique relationship to each other. Each wave should begin its rise/fall directly in the middle of the wave on the opposite line.

If the spindle was turned too fast while data was taken, the waves may appear not centered due to the pixel resolution. If this occurs, retake the data by spinning slower and review the wave pattern.

When panning in the encoder screen, the pan left or pan right will only pan the data one half of a screen at a time. This will only move the waves one half of a screen to the left or right. For example, if you are panning right and the spindle home pulse is on the right of the screen, pressing "Pan Right" once will move the home pulse to the left side of the screen and new data will be shown on the right of the screen.

To test the spindle encoder or a knob encoder, select "Diagnostics" from the second tier of the Service Mode Logo Screen.

Highlight "Rotary Encoders" from the Diagnostics (Service Mode) screen and select "Begin Selected Test."

## Spindle Encoder

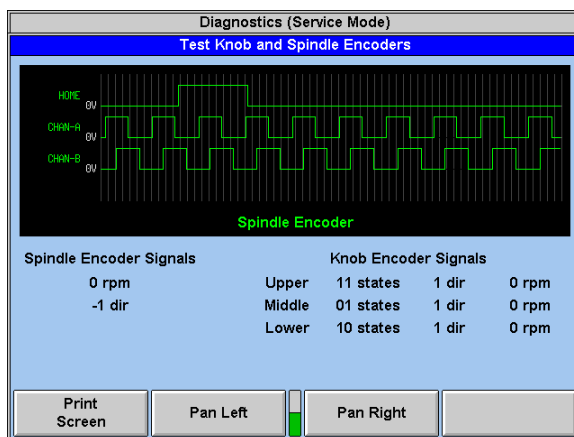

From the "Test Knob and Spindle Encoders" popup screen, select "Take Readings" while turning the spindle.

Use the "Pan Left" and "Pan Right" keys to view the readings.

The home pulse should encapsulate 1.5 waves of Channel "A" as shown above.

Turn the spindle and verify that there is no noise on the signals:

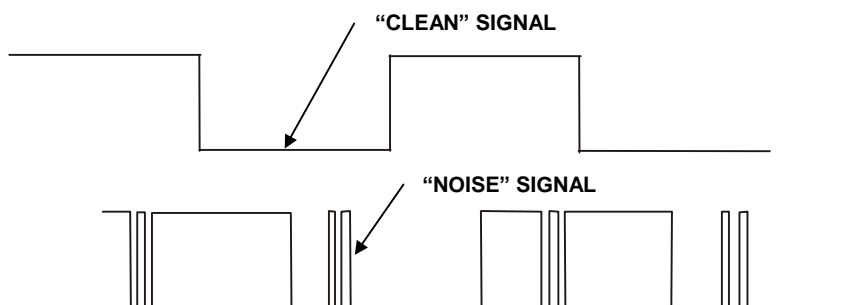

Turning the spindle clockwise will be displayed as a "positive 1" direction, counterclockwise will be displayed as a "negative 1" direction. Another indication of noise is if the display fluctuates between negative and positive 1, while turning the spindle in a constant direction.

## Knob Encoder(s)

Rotary knob encoders are 24 position switches outputting the same kind of signals as the A/B channel of the spindle encoder (they are not potentiometers).

Plots should show quadratic (2 channel) square wave pulse. Degradation is indicated by a noisy signal.

Select "Show Upper/Middle/Lower Knob" to select the suspected problem knob.

NOTE: No choices are shown for a single-knob GSP9712.

Select "Take Readings" while turning the selected knob.

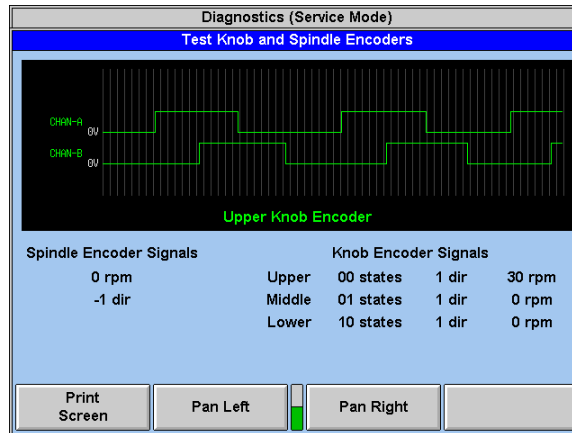

Use the "Pan Left" and "Pan Right" keys to view the readings.

Turn knobs and verify that there is no noise on channel "A" or channel "B."

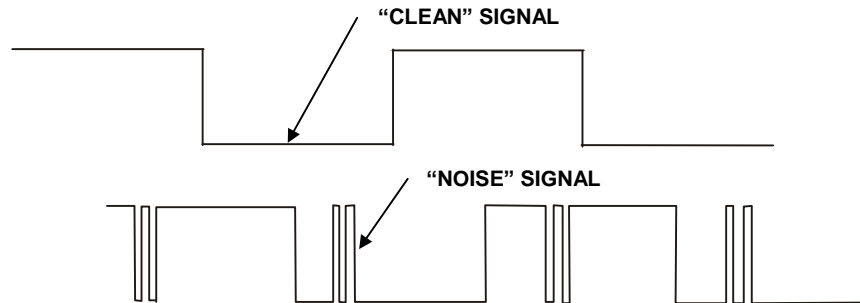

Turning knobs clockwise will be displayed as a "positive 1" direction, counterclockwise will be displayed as a "negative 1" direction. Another indication of noise is if the display fluctuates between negative and positive 1, while turning the knob in a constant direction.

---

## Keys and Switches

The keys and switches selection includes the softkey selections, the hood switch, the outer Dataset® arm switch, and the foot pedal switch.

To test the keys and switches, select “Diagnostics” from the second tier of the Service Mode Logo Screen.

Highlight “Keys and Switches” from the Diagnostics (Service Mode) screen. Each key and switch illustrated in yellow on the “Diagnostics” screen can be tested.

“Begin Selected Test” starts each test.

From the “Test Keypad and Switches” popup screen, activate each switch and then press each key. Each key and switch will beep when working properly. The “End This Test” key should be selected to end the “Keys and Switches” test after all other keys and switches have been tested.

The switches should produce a beep upon closure. This will isolate the problem to the switch itself, or to the interconnect board, interconnect cable, or the GSP board.

Also, make sure the hood switches are correctly plugged in to the interconnect board. If you get a beep in one hood direction, but not the other, swap the cables at the interconnect board to isolate the problem. Swapped hood cables will produce a beep upon closure in Diagnostics, but will still cause incorrect operation. For example, reversed hood cables on the interconnect board will cause hood autostart to work when the hood is lifted, rather than when closed.

---

## Data Acquisition Circuits

To test the data acquisition circuits, select “Diagnostics” from the second tier of the Service Mode Logo Screen.

Highlight “Data Acquisition Circuits” from the Diagnostics (Service Mode) screen and select “Begin Selected Test.”

Selecting “Data Acquisition Circuits” will provide real time numbers for each channel.

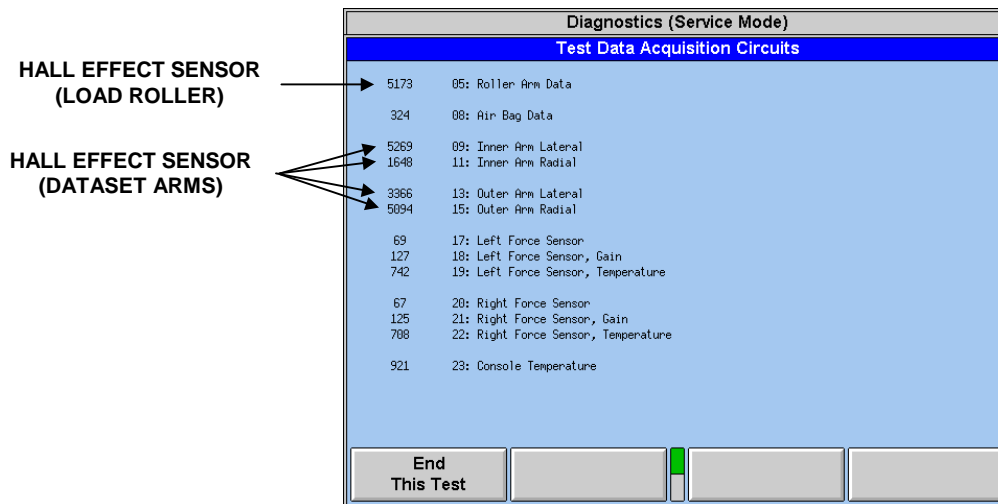

When testing the Hall effect circuits, the approximate range for the sensor circuits is 1100 - 6800. Due to the allowed range of motion for each Dataset® arm, the extents of this range may not always be obtainable by each channel.

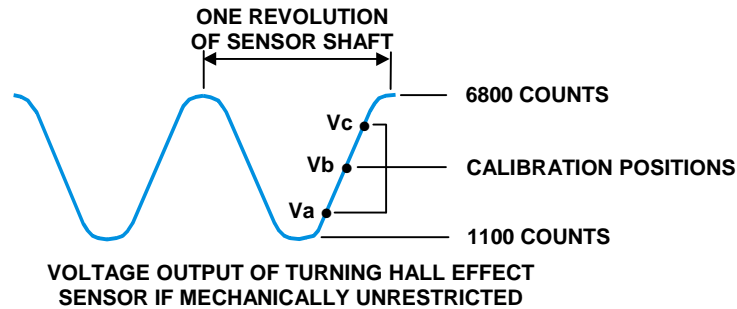

With the exception of the inner arm radial sensor, outputs are mechanically restricted to operate in the increasing portion of the sensor output as shown above. The inner arm radial can operate in the down as well as the up position, therefore has two sets of 3-point calibrations in its cal procedure. Its response (the numbers you see on the screen) will increase, peak, and then decrease as it is moved through its range.

**Verify that Hall effect sensors are operating:**

05: Roller Arm Data  $5200 \pm 300$  at home position and decreases as it is pulled forward.

09: Inner Arm Lateral  $5700 \pm 400$  at home position and decreases to  $3100 \pm 400$  at full extended position.

11: Inner Arm Radial  $2300 \pm 400$  with arm resting on top of spindle tube and increases to peak value as arm is pointed directly away from spindle, then decreases to  $1900 \pm 400$  with arm touching bottom of spindle tube.

13: Outer Arm Lateral  $5900 \pm 400$  with arm as far left as it will go, decreasing to  $3600 \pm 400$  at home (hood up) position.

15: Outer Arm Radial  $2500 \pm 400$  with hood down, increasing to  $4700 \pm 400$  as hood is lifted to up position.

The above checks show only that the sensors are operating and the polarity is correct. For further accuracy in checking that a sensor is “centered” correctly (sensor installed rotational position causes the middle cal point Vb to be near the middle of the increasing portion of the sensor output), the above values must be checked at the actual calibration positions, using calibration tool, 221-602-1. Calibration may be performed to view cal point values for the current condition of the sensor(s). Refer to “Appendix D - Cal Position Values and Tolerance Checks,” page 8-1.

If a channel gives a reading of approximately 100 or less, it is indicating a dead signal. This could be caused by an unplugged or broken wire, or a bad sensor.

Once a problem sensor is found, its cable to the interconnect board may be swapped with the other sensor on the same arm. Check sensor response with the cables swapped. (Example – swap the inner radial cable with the inner lateral cable.) Remember now the response you see on the screen to inner radial movement is being produced by the inner lateral sensor and vice versa. This same procedure can be used with the outer arm.

This will isolate the problem to the sensor itself, or to the interconnect board, interconnect cable, or the GSP board.

If the problem seems to be in the sensor, check the magnet locator assembly for looseness. It is keyed to the shaft, and secured with a screw in the center.

### Verify Force Sensor Readings:

Both force and “Gain” values will go positive and negative when the shaft is pushed and pulled. + 8191 and - 8192 indicate clipping (push/pull exceeded maximum imbalance force measurable). These values are invalid with the balancer structure at rest.

Force sensor “Gain” readings should be four times the corresponding force reading, therefore will clip four times as easily as the force values.

### Verify Console Temperature Readings:

Temperature readings for each force transducer should be within 50 counts of each other, and be in the range of 700-900, depending on ambient temperature.

Temperature readings should increase with temperature rise.

Console temperature readings should be in the range of 800 - 1100, depending on ambient temperature. This sensor (U35 on the GSP board) is the same as in the force sensors, but yields higher output due to the heat sources in the console.

---

## Dataset® Arm Sensors

To test the Dataset® arm sensors, select “Diagnostics” from the second tier of the Service Mode Logo Screen.

Highlight “Dataset Arm Sensors” from the Diagnostics (Service Mode) screen and select “Begin Selected Test.”

If a runout spin was previously performed in balance mode, two revolutions of data will be shown. The tests are divided into the “Inner Lateral,” “Inner Radial,” “Outer Radial,” and “Outer Lateral.” Within each test, you have the option of zooming in and out and panning left and right by a half of a screen for each key press.

To take new data while on this screen, mount a wheel assembly and apply the Dataset® arms to the inner and outer rim, then press the outer arm switch to begin taking readings.

Look for noise and sensor response in radial and lateral directions. A “perfect wheel” that has no runout, will give a flat line response (the same as if the sensor is not working). If this situation occurs, simply input a small amount of runout manually (by pulling on the Dataset® arm slightly). If a flat line response is still indicated, the sensor should be replaced.

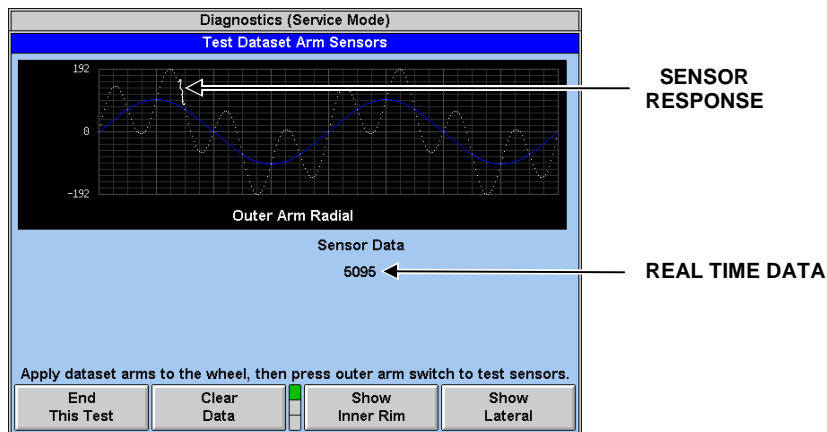



## Loaded Runout Sensor

To test the load roller sensor, select “Diagnostics” from the second tier of the Service Mode Logo Screen.

Highlight “Loaded Runout Sensor” from the Diagnostics (Service Mode) screen and select “Begin Selected Test.” If a loaded spin was previously performed in balance mode, four revolutions of data will be shown.

Press “Start” to acquire new data while on this screen. You will be instructed to mount a wheel assembly, then press “OK” to start wheel turning. You may collect the data in either of the two following ways:

Move the load roller arm so the load roller makes contact with the moving wheel, then press “Null Runout” to enter the initial arm position. Press “Take Readings” while holding the load roller against the wheel assembly.

Or, press “Null Runout” to enter the initial arm (resting) position. Press “Take Readings” and just pull the load roller forward (stay under 1/2 inch movement to avoid “clipping”) a few times to collect data.

Inspect the corresponding data. The number of peaks or valleys should correspond to the runout in the wheel assembly, or to the number of times that the load roller was pulled forward (if moved manually).

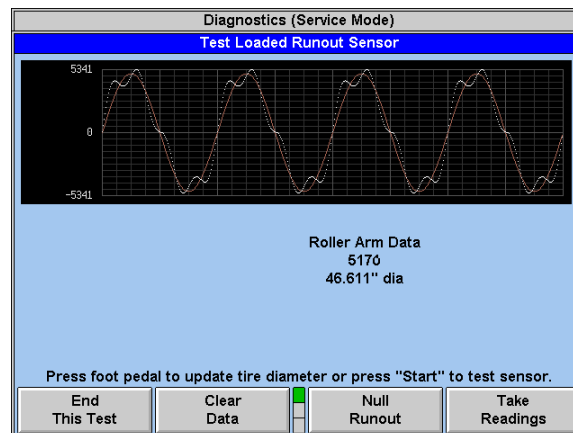

## Diameter Accuracy Verification

This screen may also be used to verify the measured diameter. To measure a diameter:

Mount an assembly with a known diameter, or place the calibration tool on the middle load roller slot.

Pull the load roller to touch the mounted assembly or the calibration tool.

Step on the foot pedal.

Verify the diameter on the “Test Loaded Runout Sensor” screen is equal to the diameter of the assembly, or 30.000 (GSP9702) or 30.168 (GSP9712) inches if using the center slot of the calibration tool.

---

## Loaded Runout Air Components

Selecting “Loaded Runout Air Components” tests the “add air” valve, “hold air” valve, and air bag, using manual controls. *Refer to “Inflation Station System Schematic,” page 6-5.*

Select “Diagnostics” from the GSP9700 Service Mode logo screen.

Highlight “Loaded Runout Air Components” and select “Begin Selected Test.”

Securely mount a medium to small sized wheel assembly onto the GSP9700.

<b>NOTE:</b>	The load roller should <b>NEVER</b> be actuated without a rim and tire assembly mounted. Over extending the air bag may cause air bag damage.
--------------	---

With the hood closed, select “Fill Air Bag” from the “Test Loaded Runout Air Components” popup screen.

When the air pressure reaches approximately 60 psi, select “Stop Filling Air Bag.”

 <b>CAUTION:</b>	“Fill Air Bag” is a <b>manual control</b> of the air bag. Software does <b>NOT</b> limit the air applied.
---	---

Then wait one minute. Pressure will drop approximately 5 psi.

Continue watching the psi reading for the air bag. The psi should not drop more than 1 psi in the next 30 seconds.

If an air leak is detected, check all lines and hoses for cracks or pinholes. Check all fittings for leaks. If fittings must be replaced, Teflon thread compound should be used on the new fitting to prevent leaks in the future.

<b>NOTE:</b>	Excess thread compound may clog air fittings and cause a pneumatic failure.
--------------	---

If no air leak is detected, select “Exhaust Air Bag.”

## DC Motor/Drive

Draws approximately 9 amps from AC line during heaviest load spinning.

Brushes are field serviceable. Route all cables away from drive housing and motor, if possible.

**⚠ DANGER:** Before doing any service work to the DC Motor/Drive, turn the GSP9700 "OFF" and disconnect the electrical power cord from the power source.

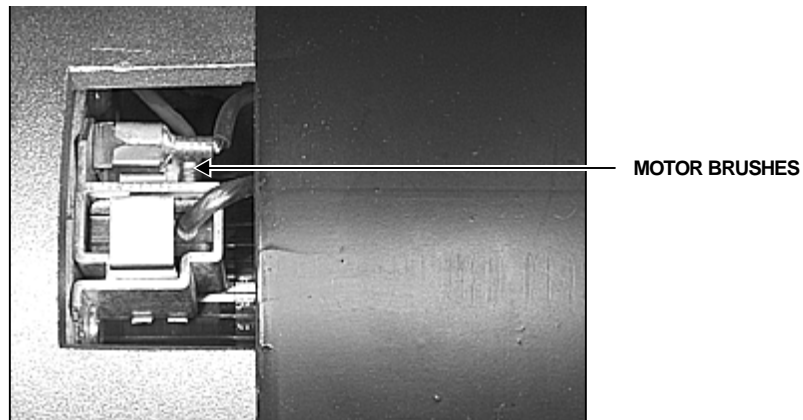

**⚠ DANGER:** Do NOT operate or plug in the unit unless the motor drive box is bolted to the cabinet and the cabinet is properly grounded!

Do NOT attempt to service the DC Motor/Drive. This is NOT a field serviceable item and any attempt to open the box and service it may result in severe personal injury or death!

The balancer uses a DC motor and a self-contained driver. The balancer motor is driven by a **390 VOLT DC** signal, switching polarity at 21KHz (21,000 times per second) **EVEN IF THE SPINDLE IS NOT TURNING DURING SERVOING.**

The pulse width in each polarity direction (duty cycle) determines how much net torque (current) is delivered to the motor. When the duty cycle is 50%, each direction is experiencing an equal pulse width and therefore, no spindle motion will occur. If the duty cycle percentage is increased above 50%, the spindle will turn one direction. If the duty cycle is decreased below 50%, the spindle will turn in the opposite direction.

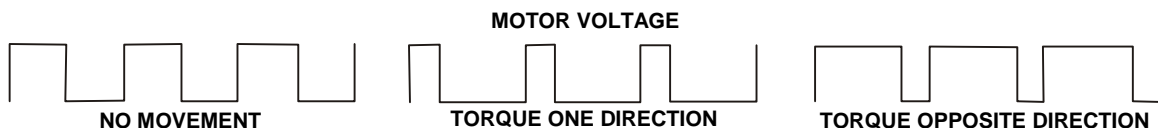

Think of this as having a 390 volt battery wired to the motor. The motor turns in one direction. If those lead wires are disconnected, and then connected in the opposite manner, the motor would start turning in the opposite direction. The drive applies this reversal at the high frequency of 21 KHz to get the current reversal hum in the motor above the audible range.

Two connections on the DC drive box provide 220 volt AC voltage. One connection is used to power the upper console, while the other is used to power the fan. The two connections are identical, therefore, interchangeable.

To test the DC motor drive, select “Diagnostics” from the second tier of the Service Mode Logo Screen.

Highlight “Motor Drive” from the Diagnostics (Service Mode) screen and select “Begin Selected Test.”

From the “Test Motor Drive” popup screen, you may test the motor drive speed or torque under manual control via the knob(s) on the console.

To test speed control, select “Test Speed,” close the hood and press “START.” Adjust the speed using the corresponding knob. Actual speed should agree within 5 rpm.

To test torque control, select “Test Torque,” close the hood, and press “START.” Use the 1st knob to adjust torque in both directions. It is **recommended** to adjust the knob only slightly in each direction to verify movement, otherwise the shaft will reach well over 330 rpm and will not stop unless the torque is dialed in the opposite direction.

<b>NOTE:</b>	Increasing torque above approximately 98% or below approximately 2% will shut off the drive until enable is toggled by pressing “STOP” and then pressing “START.”
--------------	---

An indication of the drive status is available by viewing the five LED’s mounted on the circuit board. From top to bottom, the LED’s indicate the following:

**1st GREEN: DRIVE ON**

The green LED on top indicates that the **motor lead output terminals are being driven with high voltage**. It will be off until the “Motor Enable,” 2nd green LED, is on and it is attempting to drive the motor. If the motor is disconnected, but the drive is still in an “on” condition, the LED will still be illuminated.

**2nd GREEN: MOTOR ENABLE**

This green LED indicates the motor enable signal is present from the GSP Board. This LED will turn on when the GSP board is attempting to drive the motor.

**1st YELLOW: TORQUE**

The 1st yellow LED indicates that the 400hz “torque” digital signal is present from the GSP Board. This is the same “torque” signal that the test screen has manual control of with knob 1. If this connection is intermittent, this LED will turn off, and the drive will not operate.

**2nd YELLOW: WATCHDOG**

The 2nd yellow LED indicates the watchdog signal is present from the GSP board. This is a software controlled 2hz signal (red LED on GSP board) that must be present for the drive to operate. If the GSP Board has a software or hardware problem, this signal will die and prevent further operation of the drive.

**RED: FAULT**

Indicates a fault within the drive or a lack of the required “torque” and “watchdog” signals from the GSP Board.

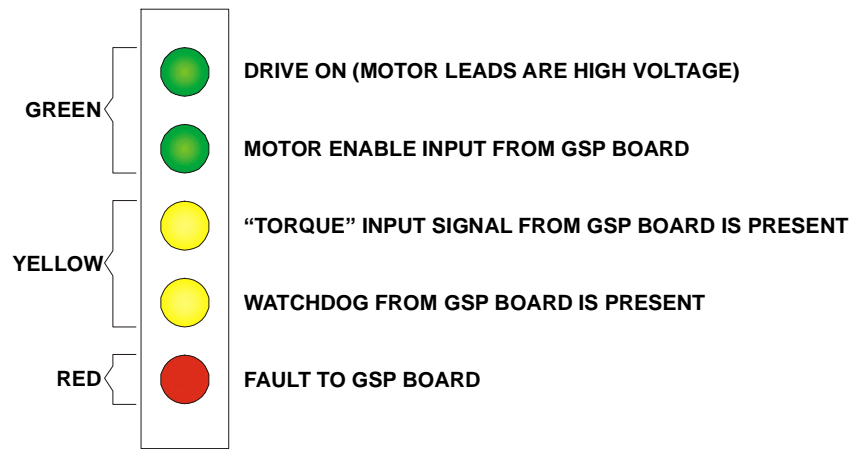

**⚠ WARNING:** The top "Drive On" LED is on even when the wheel is servoing in position (no shaft movement produced). The voltage present at the motor leads is still as potentially lethal as during a spin.



# 4 .Troubleshooting

“Service Mode Diagnostics” can be toggled by holding down the “K2” and “K3” softkeys simultaneously while pressing the reset button twice. The logo screen title should change to “GSP9700 Service Mode.” Select “Diagnostics” from the logo screen. As you scroll through the different diagnostic text, the illustration changes to highlight the selected testable components in yellow.

**NOTE:** If the GSP9700 title does not change to “Service Mode Diagnostics,” you may have old software. To access the “Service Mode Diagnostics,” turn the power off and back on while holding down the “K2” and “K3” softkeys simultaneously. Wait approximately six seconds for the GSP9700 to “boot up.”

---

## Calibration Data Error Codes

### Understanding the Force Transducer Error Codes

What is stored and/or computed at each calibration step:

**Spin 1:** Left and right transducer samples and L, R, and console temperature probes (console probe is on GSP board).

**“Enter TDC”:** Spindle encoder count at physical Top Dead Center (#23 on result screen)

**Spin 2:** Left and right transducer samples and L, R, and console temperature probes (console probe is on GSP board).

**Spin 3:** Left and right transducer samples and L, R, and console temperature probes (console probe is on GSP board).

### Default calibration check values that are loaded when calibration begins.

	Service Mode Value	Standard Mode Value	Description
ULimitT_Xdcr	1032	1487	Upper Limit Temperature Transducer
LLimitT_Xcdr	424	100	Lower Limit Temperature Transducer
ULimitT_Console	1487	2093	Upper Limit Temperature Console
ULimit_lbm	896	1344	Upper Limit Left Bare Magnitude
ULimit_rbm	3071	4606	Upper Limit Right Bare Magnitude
ULimit_lsm	1890	2450	Upper Limit Left Static Magnitude
LLimit_lsm	910	350	Lower Limit Left Static Magnitude
ULimit_rsm	6480	8400	Upper Limit Right Static Magnitude
LLimit_rsm	3120	1200	Lower Limit Right Static Magnitude
PhzdifMax	0.5 degrees angle	2.0 degrees angle	Maximum Phase Difference

## Calibration Failure

When the calibration fails, you should perform calibration in the Service Mode in order to view calibration error codes. **Keep in mind that when calibration is performed in Service Mode, the calibration will be stored even if it fails.**

NOTE:	In the standard balance mode, calibration is not stored if calibration fails. The balancer will revert to the previous calibration.
-------	---

Select "Show Calibration Data" **after** calibrating in the Service Mode.

NOTE:	This key is not present if you are not in the Service Mode.
-------	---

From the "Results" popup screen, examine the "Cal Bit Status." It has 16 digits. If everything is working properly, all 16 digits should be 1. If any digits are showing a "0" instead of a "1," an error has occurred. You will need to count from **right to left** to determine which bit(s) have a "0."

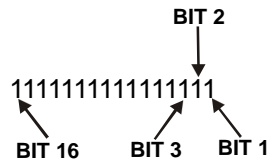

When any or all bits have failed, you should perform the same troubleshooting steps. Try **physically swapping** the force transducers to determine if the problem is the force transducer. If it isn't the force transducer, then the Interconnect board, 37-pin cable, and the GSP Board, 45-715-3, are the other possibilities.

It is also possible (and typical in many cases) for there to be multiple "0's" displayed. Most likely, the failures will all correspond to a single component failure.

## 3-Spin Calibration Failure

**Bit 1** is verifying item #24 (Spin 1 left magnitude) on the Cal Data screen is within tolerance. Item 24 verifies the cal weight was installed during the first cal spin. **If this bit fails, there is something wrong with the Left Force Transducer circuit.**

**Bit 2** is verifying item #26 (Spin 2 left magnitude) on the Cal Data screen is within tolerance. Item 26 verifies the cal weight was installed during the second cal spin. **If this bit fails, there is something wrong with the Left Force Transducer circuit.**

**Bit 3** is verifying item #43 (Bare shaft magnitude - left transducer) on the Cal Data screen is under tolerance. **If this bit fails, there is something wrong with the Left Force Transducer circuit.** Confirm that the procedure is performed properly. It is also possible that the shaft and spindle assembly is too far out of balance.

**Bit 4** is verifying item #44 (Bare shaft magnitude - right transducer) on the Cal Data screen is within tolerance. **If this bit fails, there is something wrong with the Right Force Transducer circuit.** It is possible that the shaft and spindle assembly is too far out of balance.

**Bit 5** is verifying item #25 (weight location spin 1) and item #27 (weight location spin 2) are 180 degrees out of phase with each other. **If this bit fails, it would indicate that the calibration weight was not switched between calibration spins 1 and 2.**

**Bit 6** is verifying the cal weight was switched from the inner plane to the outer plane between cal spins 2 and 3. **If this bit fails, it would indicate that the calibration weight was not switched to the outer plane between calibration spins 2 and 3 or that there is a problem with the Left Force Transducer circuit.** Confirm that the procedure was done properly.



**Bit 7** is verifying the cal weight was placed in the same hole when switched from the inner plane to the outer plane between cal spins 2 and 3. **If this bit fails, it would indicate that the calibration weight was not using the same hole when switched to the outer plane between calibration spins 2 and 3 or that there is a problem with the Left Force Transducer circuit.** Confirm that the procedure was done properly.

**Bit 8** is verifying item #32 (right transducer magnitude - spin 2) on the Cal Data screen is within tolerance. **If this bit fails, this would indicate that there is a problem with the Right Force Transducer circuit.**

**Bit 9** is verifying item #14 on the Cal Data screen is within tolerance. This is checking the left temperature probe, which is part of the Force Transducer. **If this bit fails, this would indicate that there is a problem with the Left Force Transducer circuit.**

**Bit 10** is verifying item #15 on the Cal Data screen is within tolerance. This is checking the right temperature probe, which is part of the Force Transducer. **If this bit fails, this would indicate that there is a problem with the Right Force Transducer circuit.**

**Bit 11** is verifying item #16 on the Cal Data screen is within tolerance. This is checking a temperature probe that is on the GSP board. **If this bit fails, this would indicate that there is a problem with the GSP board.**

**Bits 12-16** are not used.

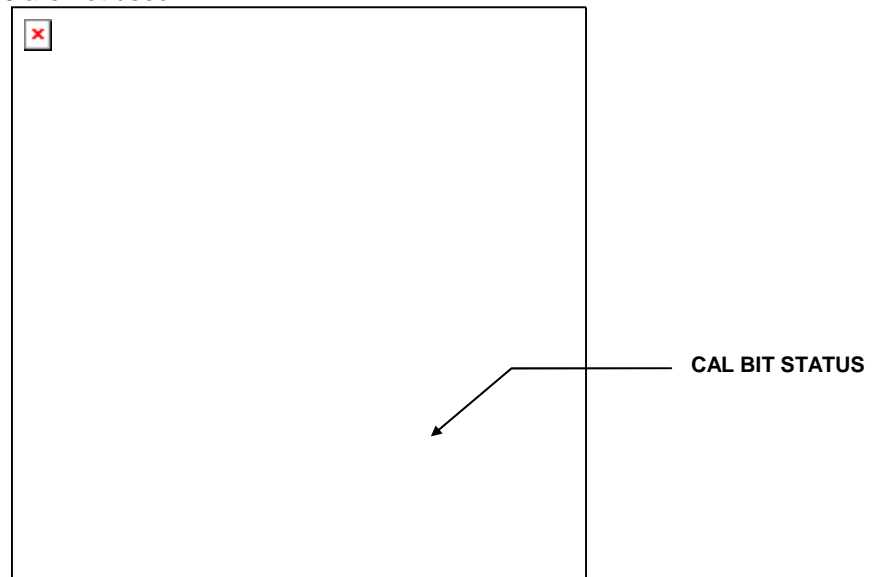

### Inner Dataset® Arm Calibration Failure

**Bit 1** is verifying that the difference between item #3 and #2 on the Cal Data screen is within tolerance. This bit checks the readings in radial steps 2 and 3 of the inner Dataset® calibration. **If this bit fails, there is something wrong with the inner Dataset® diameter sensor circuit or the correct calibration sequence was not followed.**

**Bit 2** is verifying that the difference between item #2 and #1 on the Cal Data screen is within tolerance. This bit checks the readings in radial steps 1 and 2 of the inner Dataset® calibration. **If this bit fails, there is something wrong with the inner Dataset® diameter sensor circuit or the correct calibration sequence was not followed.**

**Bit 3** is verifying that the difference between item #1 and #14 on the Cal Data screen is within tolerance. This bit checks the readings in radial steps 1 and the initial storing of the home settings of the inner Dataset® calibration. **If this bit fails, there is something wrong with the inner Dataset® diameter sensor circuit or the correct calibration sequence was not followed.**

**Bit 4** is verifying that the difference between item #9 and #8 on the Cal Data screen is within tolerance. This bit checks the readings in radial steps 5 and 6 of the inner

Dataset® calibration. **If this bit fails, there is something wrong with the inner Dataset® diameter sensor circuit or the correct calibration sequence was not followed.**

**Bit 5** is verifying that the difference between item #8 and #7 on the Cal Data screen is within tolerance. This bit checks the readings in radial steps 4 and 5 of the inner Dataset® calibration. **If this bit fails, there is something wrong with the inner Dataset® diameter sensor circuit or the correct calibration sequence was not followed.**

**Bit 6** is verifying that the difference between item #37 and #26 on the Cal Data screen is within tolerance. This bit checks the readings in lateral step 1 and the initial storing of the home settings of the inner Dataset® calibration. **If this bit fails, there is something wrong with the inner Dataset® distance sensor circuit or the correct calibration sequence was not followed.**

**Bit 7** is verifying that the difference between item #26 and #25 on the Cal Data screen is within tolerance. This bit checks the readings in lateral step 1 and 2 of the inner Dataset® calibration. **If this bit fails, there is something wrong with the inner Dataset® distance sensor circuit or the correct calibration sequence was not followed.**

**Bit 8** is verifying that the difference between item #25 and #24 on the Cal Data screen is within tolerance. This bit checks the readings in lateral step 2 and 3 of the inner Dataset® calibration. **If this bit fails, there is something wrong with the inner Dataset® distance sensor circuit or the correct calibration sequence was not followed.**

Bits 9-16 are not used.

Calibration Procedures (Service Mode)			
Inner Dataset Calibration			
Results			
1541	01: Va	DIA SENSOR, UPPER POS	2613
1009	02: Vb		3930
2355	03: Vc		4966
-1.0951	04: Theta		0.2039
2601.9638	05: M		2693.2795
4222.1497	06: H		3402.7896
5855	07: Va	DIA SENSOR, LOWER POS	2695
6404	08: Vb		3930
6665	09: Vc		4958
1.1029	10: Theta		0.2039
2638.2252	11: M		2693.2795
4049.3959	12: H		3402.7896
48.6796	13: Gain		48.9610
1959	14: Home		5242
---	15: inch, UPPER POS Diameter		---
---	16: deg, Sensor Theta		---
---	17: deg, Alpha Contact Point		---
---	18: inch, LOWER POS Diameter		---
---	19: deg, Sensor Theta		---
---	20: deg, Alpha Contact Point		189.2761
5.8861	21: H		44
-10.5888	22: K		1
111	23: 12:00 position offset, ALU		111111111110001
			24: Calibrated Flag
			25: Cal Status Bits (0 = FAIL)

CAL BIT STATUS

**NOTE:** When any or all of the bits have failed, you should perform the same troubleshooting steps. Make sure the procedure was performed properly. Try swapping the hall effect sensor connectors at the interconnect board to determine if the problem is the hall effect sensor. If it isn't the hall effect sensor, then the Interconnect board, 37-pin cable, and the GSP board are the other possibilities.

### Outer Dataset® Arm Calibration Failure

**Bit 1** is verifying that the difference between item #14 and #3 on the Cal Data screen is within tolerance. This bit checks the readings in radial cal step 3 and the initial storing of the home settings of the Outer Dataset® calibration. **If this bit fails, there is something wrong with the outer Dataset® diameter sensor circuit or the correct calibration sequence was not followed.**

**Bit 2** is verifying that the difference between item #3 and #2 on the Cal Data screen is within tolerance. This bit checks the readings in radial steps 2 and 3 of the Outer Dataset calibration. **If this bit fails, there is something wrong with the outer Dataset® diameter sensor circuit or the correct calibration sequence was not followed.**

**Bit 3** is verifying that the difference between item #2 and #1 on the Cal Data screen is within tolerance. This bit checks the readings in radial steps 1 and 2 of the Outer Dataset calibration. **If this bit fails, there is something wrong with the outer Dataset® diameter sensor circuit or the correct calibration sequence was not followed.**

**Bit 4** is verifying that the difference between item #26 and #25 on the Cal Data screen is within tolerance. This bit checks the readings in lateral steps 1 and 2 of the Outer Dataset calibration. **If this bit fails, there is something wrong with the outer Dataset® distance sensor circuit or the correct calibration sequence was not followed.**

**Bit 5** is verifying that the difference between item #25 and #24 on the Cal Data screen is within tolerance. This bit checks the readings in lateral steps 2 and 3 of the Outer Dataset calibration. **If this bit fails, there is something wrong with the outer Dataset® distance sensor circuit or the correct calibration sequence was not followed.**

**Bit 6** is verifying that the difference between item #37 and #26 on the Cal Data screen is within tolerance. This bit checks the readings in lateral step 1 and the initial storing of the home settings of the Outer Dataset calibration. **If this bit fails, there is something wrong with the outer Dataset® distance sensor circuit or the correct calibration sequence was not followed.**

Bits 7-16 are not used.

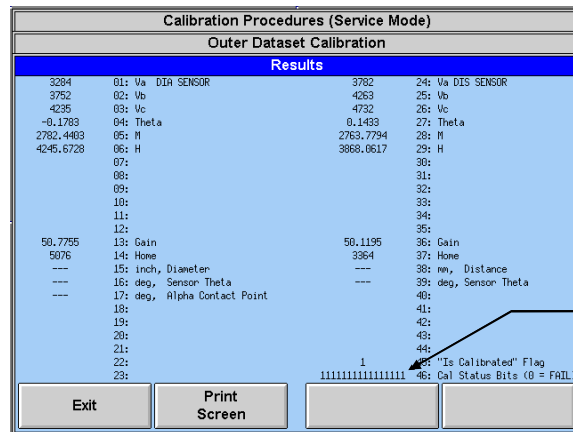

**NOTE:** When any or all of the bits have failed, you should perform the same troubleshooting steps. Make sure the procedure was performed properly. Try swapping the hall effect sensor connectors at the interconnect board to determine if the problem is the hall effect sensor. If it isn't the hall effect sensor, then the Interconnect board, 37-pin cable, and the GSP board are the other possibilities.

## Load Roller Calibration Error Codes

**Bit 1** is verifying that the difference between item #14 and #3 on the Cal Data screen is within tolerance. This bit checks the readings in radial cal step 3 and the initial storing of the home settings of the Load Roller calibration.

**Bit 2** is verifying that the difference between item #3 and #2 on the Cal Data screen is within tolerance. This bit checks the readings in radial steps 2 and 3 of the Load Roller calibration.

**Bit 3** is verifying that the difference between item #2 and #1 on the Cal Data screen is within tolerance. This bit checks the readings in radial steps 1 and 2 of the Load Roller calibration.

**Bits 4-16** are not used.

Calibration Procedures (Service Mode)			
Load Roller Calibration			
Results			
3330	01: Va	DIA SENSOR	24:
3985	02: Vb		25:
4632	03: Vc		26:
0.0466	04: Theta		27:
2518.0087	05: M		28:
3867.6090	06: H		29:
	07:		30:
	08:		31:
	09:		32:
	10:		33:
	11:		34:
	12:		35:
50.3784	13: Gain		36:
5172	14: Home		37:
---	15: inch, Diameter		38:
---	16: deg, Sensor Theta		39:
---	17: deg, Alpha Contact Point		40:
	18:		41:
	19:		42:
	20:		43:
	21:		44:
	22:		45:
	23:		46:
		1	"Is Calibrated" Flag
		11111111111111111111	Cal Status Bits (0 = FAIL)

CAL BIT STATUS

## Servo Stop Calibration Error Codes

“Zero Torque Bias” (#1) indicates the required duty cycle above or below the nominal 50% duty cycle to achieve zero torque on the spindle.

**Bit 1** is verifying that the zero torque is not greater than 5%. If it exceeds 5%, then #1 on this screen will show 5% and #4 will appear to indicate the large positive zero torque computed by the calibration. **If this bit fails and #4 is below 10%, try replacing the DC motor drive supply or the motor. If #4 is above 10%, contact the Repair Lab.**

**Bit 2** is verifying that the zero torque is not less than -5%. If it is less than -5%, then #1 on this screen will show -5% and #4 will appear to indicate the large negative zero torque computed by the calibration. **If this bit fails and #4 is above -10%, try replacing the DC motor drive supply or the motor. If #4 is below -10%, contact the Repair Lab.**

**Bits 3-16** are not used.

Calibration Procedures (Service Mode)			
Motor Control Calibration			
Results			
1.61 %	01: duty cycle, zero-torque bias		24:
50.00 %	02: duty cycle, zero-torque nominal		25:
	03:		26:
	04:		27:
	05:		28:
	06:		29:
	07:		30:
	08:		31:
	09:		32:
	10:		33:
	11:		34:
	12:		35:
	13:		36:
	14:		37:
	15:		38:
	16:		39:
	17:		40:
	18:		41:
	19:		42:
	20:		43:
	21:		44:
	22:		45:
	23:		46:
		1	"Is Calibrated" Flag
		11111111111111111111	Cal Status Bits (0 = FAIL)

CAL BIT STATUS

---

## Interconnect Board, 45-825-1

Being an interconnect for nearly all the sensors and input switches makes this board a first place to look when suspecting intermittent connection problems. Temporarily swapping Dataset® cables, force transducer cables, and/or mechanical switch inputs can help pinpoint broken connector headers, board traces, etc.

Substituting a known good 37-pin Dsub communication cable (J1) may reveal Dsub socket problems.

U4 (hose attached) is an air pressure sensor. Check that the plastic nipple at the hose attachment is not broken or leaking (perform leak-down test). Refer to "Loaded Runout Air Components," page 3-10.

U1 is a microprocessor that runs independent checks of the hood switches, spindle encoder rpm, and attempts by the GSP board to turn on the DC drive. The LED on the interface board blinks to signal U1 is running. If motor fault occurs, the LED will blink at a faster rate...GSP is responsible for seeing the fault and shutting off the drive. U1 has the final say if the air valves can turn on and if the DC drive can turn on **regardless** of what the GSP is attempting to do. This provides redundant safety in case a problem arises with the GSP board but also increases the chance of air and motor functions being prevented when the interconnect board or its inputs have a problem. Referring to the interface board schematic in Appendix C, the logic that U1 uses to allow the air bag and motor functions is:

Air valves disabled if:

1. Motor is on (GSP is trying to enable the DC drive) AND any of the following:
  - hood is not full down (hood down switch is not closed)
  - hood is full up (hood up switch is closed)
  - rpm is less than 30 (encoder board phase signals not changing fast enough)
2. Motor is off AND hood is not full down (hood down switch is not closed)
3. Hood is full up (hood up switch is closed)

Motor disabled if:

1. "Watch dog" signal (red LED on GSP board in console) is inactive for 1 second.

DC drive torque limited if:

- hood is not full down (hood down switch is not closed)
2. Hood is full up (hood up switch is closed)

From these rules being *continuously* checked by U1, it should be apparent that the **hood switches must be working properly and their signals must be intact to both U1 on the interconnect board as well as to the GSP board (through the 37-pin D-sub cable at J1) before the air or motor can function.**

---

## CRT

The CRT assembly is field serviceable only for setting brightness, contrast, size, and centering. Exchange any failed CRT.

<b>NOTE:</b>	In the event of monitor failure, a standard PC monitor can be used to keep a unit running. Use the monitor connector on the GSP board in the console to attach an external monitor. 115 volt must be provided for the temporary monitor.
--------------	--

---

## Printer

Printing problems can be caused by hardware.

Printer software problems are limited because all required interface software (i.e. printer drivers) is loaded in the balancer program cartridge.

For hardware, check the following:

- Verify illuminated LED's on the printer and printhead movement when power is applied.
- If the printer does have power, perform the printer's built-in self-test. On the standard Okidata Dot Matrix Printer, press the "Line Feed" button while turning the printer power ON. The test should produce a one page test printout. While this does not prove that the printer is not defective, printers that self-test correctly are usually operational.
- Verify that the printer data cable is securely connected to the printer and the bottom of the CRT console.

The 311 printer, 167-69-1, will work on the GSP9700. The dot matrix printer (184T with rev 3.0.1 software) is the only supported printer. You will also need power cable, 38-485-2, and data cable, 38-657-2.

---

## Identifying Mechanical Mounting Repeatability Errors

Chasing weights, changing weight angles, changing weight amounts and changes in runout and force variation may all be produced by incorrect mounting or worn/damaged adaptors. The GSP9700 cannot identify subtle mechanical mounting errors due to the use of incorrect mounting methods or worn/damaged mounting adaptors. Correct mounting must be done by the technician, including identifying the on-vehicle mounting method. Adaptors must be inspected for excessive wear and should be cleaned regularly to prevent dirt from affecting the balancer results.

Before checking for mechanical mounting errors, perform a Quick Cal Check to verify accurate balancer calibration. Look at the calibration readings to verify weight angle position and view the non-rounded weight readings. The weight should be approximately 4.31oz for one plane and 0 oz for the opposite plane with the default "A" width and diameter dimensions (224, 4.9, 14).

### To test mechanical mounting repeatability:

Mount an assembly on the spindle shaft.

Input the weight location dimensions.

Measure and record the non-rounded amount of imbalance on each weight plane.

Repeat this procedure four times without removing the wheel to verify the balancer can repeat measurements within 0.05 ounce. If it does not repeat the measurements, check the wheel for debris or water in the tire.

With the assembly mounted on the spindle shaft, perform a balance spin with the load roller enabled.

Record the non-rounded weight amounts for the inner and outer planes. Do not apply weights.

When the data is recorded, loosen the wing nut and using the foot pedal to lock the spindle in position, rotate the wheel 90 degrees clockwise. Perform another balance spin with the load roller enabled. Record the non-rounded weight amounts for the inner and outer planes.

Repeat the above steps twice more so measurements are taken at 0, 90, 180, and 270 degrees. If all recorded readings change by more than 0.30 ounce, repeat the measurements at 0, 90, 180, and 270 degrees again.

### Data Analysis:

NOTE:	Larger rim/tire assemblies may experience more variation in data than smaller assemblies. This should be factored in when comparing data.
-------	---

The weight amount for a medium size, passenger car wheel should not vary more than 0.30 ounce from the highest to lowest recorded number. This means that the imbalance measurement is + or - 0.15 ounce from the true wheel imbalance.

**If ALL readings change, BUT the readings from the first sample data and the second sample data are the same for 0, 90, 180, and 270 degrees, the hub/shaft assembly is out of position.** Use a dial indicator to check for runout on the hub face and on the shaft. Runout on the hub face should not exceed 0.0015 inch. Runout on the shaft should not exceed 0.0015 inch. If runout exceeds these limits, remove the threaded hub/shaft assembly and inspect for any debris or nicks on the tapered mounting surfaces. Remove any nicks using a fine grit stone removing only the raised portion of the metal around the nick. Do **NOT** use sandpaper! Clean parts and lightly oil before reassembling and measuring for runout again.

**If the imbalance amounts change and the readings from the first sample data and the second sample data are NOT the same for 0, 90, 180, and 270 degrees, the assembly is not being mounted correctly.**

Improved Mechanical Mounting Error Detection is available in GSP9700 Software Version 1.2 and higher. If the software detects similar radial/lateral runout motion (parallel dial indicator gauge deflection) at both rim lips, it will warn the user that there is a possible mounting error. This does not compensate for all mechanical mounting errors or for worn/damaged adaptors, but it does identify gross mounting errors.

To demonstrate the GSP9700 Mounting Error Detection, place a business card folded in half between the hub face and the wheel during mounting. Do **NOT** use Quick-Thread®! Take rim runout measurements. The GSP9700 will warn that a mounting error has occurred.

To address a non-repeatability complaint, ask the technician to measure rim runout on the assembly. The GSP9700 may be able to detect the mounting error. If a mounting error is detected, *refer the technician to "Mounting the Wheel, Centered on the Spindle Shaft" and "On-Vehicle Wheel Mounting Methods" in the GSP9700 Series Vibration Control System Operations Instructions, Form 4202T for proper mounting techniques.*

## Troubleshooting Chart

Symptom	Possible Cause	Remedy
Unrepeatable Forcematching® results or no reduction of vibration after Forcematching®.	Rim runout is being measured using “outside” method (both arms applied to outside of rim) but these surfaces are not concentric with the actual bead seat surfaces.	Measure rim runout using the bare rim method. Some aluminum rims have roughcast surfaces at the “outside” rim runout measuring areas.  Other rims may have the bead seat surfaces turned as the last manufacturing step, leaving the “outside” surfaces with a different runout than what is affecting the tire assembly. If a rim is consistently identified as having differences in measurement after the “bare rim” and “outer” methods of measurement have been used, send in the amounts of differences observed (printouts of the runout plots are beneficial) and the wheel type so that a list of rims that <b>MUST</b> be measured with the tire removed can be compiled.
	Large rim bend or tire anomaly not recognized by pre-1.2 software.	The GSP9700 computes the “first harmonic” (once per revolution) component from ALL of the runout data recorded around the full circumference of the rim. If a rim has a large bend that is taking up a small portion of the circumference then it will cause the first harmonic to increase but not to near the same magnitude as the bend itself. This will result in a matching prediction that will not be as correct as a rim that has true “gradual” once per rev runout of the same amount. A large anomaly in a tire (such as a slipped belt) will cause the same effect. Version 1.2 software flags these cases before the matching screen appears.
	During “outside” rim runout, the arms are being placed at the rim lips (as if inputting rim dimensions) instead of on the outside surface of the bead seat portion of the rim.	For “outside” runout measurement, apply the arms to wheels as shown in the operation manual and on the measurement screens. The rim lip areas for attachment of clip-on weights does not necessarily have the same runout as the bead seats.
	During “outside” rim runout, the Outer Dataset® arm is left in the home position.	Software assumes both arms are used during the “outside” runout measurement. If a wheel has a closed face or shape that prevents the outer arm from being used, you <b>MUST</b> use the bare rim method to obtain runout. Using the “outside” method without the outer arm in the home position will cause the runout of the rim to be stored as half the actual value since the outer arm was not moving at all and its runout was recorded as zero.
	Inner arm mechanical looseness.	Check bolt tightness on the rolling V-blocks that the main shaft slides on. Check that the pivot casting which applies a pre-load to the main arm shaft is not loose and is adjusted (setscrew) to allow about 0.010” vertical movement of the pivot casting when pulling up on the right side of the main shaft. Note that this vertical movement will not translate into runout error as long as the arm is held properly. <i>Refer to “Inner Dataset® Arm,” page 2-1.</i>
	Outer arm mechanical looseness.	Check that the bolt securing the outer arm to the rear support tube is not loose. A slightly loose situation might make the arm appear to work when entering rim dimensions, but will still have large effects on the sensitive runout readings.
	Inner arm Hall effect sensors loose.	Check for screws loose on sensor casings and/or cracked casings. A telltale sign is to observe the diameter sensor while rotating the arm main shaft back and forth. If the sensor casing shifts back and forth more than approximately 0.020 inch, something is loose. This looseness will translate into incorrect runout measurements.



Symptom	Possible Cause	Remedy
Unrepeatable Forcematching® results or no reduction of vibration after Forcematching® (continued).	Not holding arm(s) correctly during runout measurement.	Hold the inner and outer arms against the wheel only with fingertip pressure, as close to the point of contact with the wheel as possible. Do NOT grab the inner arm, for example, midway between the roller tip and where it exits the balancer tray. This will place an undesirable torque on the inner arm main shaft and probably will cause the shaft to lift off the rolling v-blocks during the measurement. Small detents are provided on the arm castings for finger placement during runout measurement.
	Not applying even pressure to the Dataset® arm(s) throughout the duration of the measurement.	Do not change the force applied to the arms during the runout measurement as this will cause the arm(s) to bend. (Keep in mind we are measuring thousandths of an inch resolution) which in turn will cause the sensor angles to change (not tracking the true runout). Holding the arm(s) as close to the rim contact point(s) as possible minimizes this effect. Refer to “Measuring Rim Runout” in the GSP9700 Operation Manual, 4202T, for proper techniques.
	Rim bend conditions not recognized by pre-1.2 software.	The GSP9700 calculates the average of the inner and outer rim runouts for matching purposes. There are some bent-rim conditions that, for older software, will not be flagged as “bad,” and thus may be used in a matching procedure with unpredictable results. Cases like this are flagged by 1.2 software, however a manual diagnosis can be performed using any software version by observing the inner and outer radial runout on-screen gauges or the radial runout plots. Opposing needle deflections or opposing plot peaks hint that the wheel may have hit a curb hard. The more offset the wheel has, the easier this kind of bend can happen. An example of this is where the high spots of each side of a rim are large (>0.030) and are 90 degrees to 180 degrees from each other. Individual rim runout might show large values yet the average is near zero. Because of the opposite phase locations the average does not have an applicable amount of variation for radial matching correction.
	Multiple harmonics of FV and runout not recognized by pre-1.2 software.	Only first harmonics (once per rev) of force variation and runout are recognized by pre-1.2 software. If a rim has a large second harmonic (twice per rev., egg-shaped) then this value is filtered out (ignored) when in fact this rim should not be matched but replaced. Version 1.2 software analyzes to the 3rd (3 times per rev) harmonic.
	Tire stiffness of particular tire affecting readings on pre-1.2 software	If the tire is softer or harder than the normal range of passenger tires, there will be some errors with pre-1.2 software. In these cases the magnitude of the measured force variation, but not the angle, has some error. Because the angle is still correct, matching will still work well, as long as the result is not expected to agree exactly with the predicted value and you are not trying to match an assembly that was under limit in the first place. Version 1.2 software compensates for this extra range of tire stiffness.
	Arm calibration(s) required.	It is imperative that the arms are absolutely still during the first step of the calibration procedures. This step not only records a rough reading of the “home” position for arm triggering, but also steps through a series of voltage inputs to store permanently the sensitivities of each sensor’s runout circuit. Any movement in an arm during this step will cause errors in runout readings.
	Air bag, valve(s), or hose leak.	Check for air leaks by using the “test air components” screen. Observe the on-screen pressure reading 30 seconds after filling the bag to 70 psi. Replace hoses or valves if the pressure drops more than 5 psi per minute (initial pressure drop due to bag relaxation is normal).

Symptom	Possible Cause	Remedy
Unrepeatable Forcematching® results or no reduction of vibration after Forcematching® (continued).	Not waiting long enough with the arms positioned against the rim before pressing the outer arm button to take readings.	Do not press the outer arm button to start the measurement until the arm(s) are held steady on the rim. The instant the button is pressed the GSP9700 notes the “starting position,” nulls out the A/D values of the arm sensors, and then notes small amounts of movement from that point. If the arm button is pressed too soon, the “null” position is off and small amounts of movement during the spin actually look much larger.
	Rim is moving relative to hub during loaded portion of spin. The assembly loaded runout, rim runout, tire force variation calculation, and even the imbalance readings are all in error because of the mis-centering that results.	Insufficient clamping force can cause the rim/tire assembly to slip position while the load is applied, yet the wingnut can still be tight after the spin ends. Make sure the threads are cleaned and lubricated, the hub face and rim are clean and dry, and enough force has been applied to the wing nut. About twice the force is needed on the GSP9712 compared to normal balancers that do not have a 1400 lb. side load applied during a spin. As a rule of thumb, the wing nut should be tight enough to just cause the spindle to rotate while standing on the foot pedal. Also be sure that if the “high taper” truck cone is being used, it must be OUTSIDE coned because this cone will not fit into the hub recess when used as a back cone. (The rim will probably not even contact the hub when the wing nut is tight or if it does the centering error will be large.)
	Excessive Load Roller Runout	Check for load roller runout. 0.005 inches runout is excessive and the load roller should be replaced.
Non-repeatable Wheel Dimensions/ Balance Spins	Dataset® arm sensor looseness	Outer arm: Check that the bolt securing the arm to the rear support tube is not loose. Inner arm: Check for screws loose on sensor casings and/or cracked casings. A telltale sign is to observe the diameter sensor while rotating the arm main shaft back and forth. If the sensor casing shifts back and forth more than approximately 0.020 inch, something is loose. Make sure a cable is not being caught in the V-roller that the link rides in for the distance sensor.
	Calibration Error	Recalibrate entire balancer using the procedure as outlined in the GSP9700 Operations Manual, Form 4202T.
	Inner arm Pivot Casting	Should allow for a 0.10 inch vertical movement on the shaft at the rightmost V-roller. Verify pivot casting base attachment bolt is tight. Verify spring pressure is acting on the shaft.
	Inner arm V-rollers	Verify V-Roller bolts are tight.
	Mechanical Restriction	The inner Dataset® assembly pivot casting may be too tight or the arm may be rubbing on the weight tray.
	Mounting is offset	Verify cones are concentric and wheel is being mounted correctly. Verify wingnut is in good condition.
	Larger tire/wheel assemblies causing balancer movement (may be unobservable)	Install hold down kit to units prior to serial number AJ9393.
	Mechanical problems	<ol style="list-style-type: none"> <li>1. Check for sufficient spindle clearance at wrapper.</li> <li>2. Check that belt access cover does not touch motor mount bolt.</li> <li>3. Check for debris between vibration channel and wrapper.</li> <li>4. Check for loose force transducers.</li> <li>5. Check for sufficient brake pad clearance.</li> </ol>

Symptom	Possible Cause	Remedy
Weight amount changes with wheel remount	Calibration Error	Verify that the arms are correctly calibrated and the hood is in the raised position. If there is a mechanical problem preventing the hood from fully opening or closing, the outer Dataset® will not trigger. Also make sure the hood switches are correctly plugged in to the interconnect board. Swapped cables will produce a beep upon closure in Diagnostics, but will not allow the Dataset® arms to trigger. This will also cause the autostart on hood down to work in reverse. Verify that the wingnut has both handles installed. Removing either of these will cause an imbalance in the wingnut assembly.
Dataset® arm will not trigger	Inner arm mechanical looseness.	Check bolt tightness on the rolling V-blocks that the main shaft slides on. Check that the pivot casting which applies a pre-load to the main arm shaft is not loose and is adjusted (setscrew) to allow about 0.010 inch vertical movement of the pivot casting when pulling up on the right side of the main shaft. Note that this vertical movement will not translate into runout error as long as the arm is held properly. <i>Refer to "Inner Dataset® Arm," page 2-1.</i>
	Hood Switches	Verify hood switches are working properly. Replace if necessary.
Outer Dataset® arm will not calibrate	Outer arm mechanical looseness.	Check that the bolt securing the outer arm to the rear support tube is not loose. A slightly loose situation might make the arm appear to work when entering rim dimensions but will still have large effects on the sensitive runout readings.
"Set Dimensions" Screen pops up intermittently when hood is raised or lowered	Check for a loose screw on the outer arm hall effect sensors.	Tighten screw on outer arm. Replace Hall effect sensor, if necessary.
Inner Dataset® motor assisted adhesive weight placement moves wheel to incorrect angle.	Inner arm calibration bug with pre-1.2 software.	Re-calibrate the inner arm. Upgrade to 1.2 or later software.
Will not spin and DC drive green "Motor Enable" LED is off	Interface Cable Connection	Check the Interface Cable Connection between the Interface Board and the GSP Board. Replace the Interconnect Board or GSP Board, if necessary.
Will not spin and DC drive yellow Torque LED is Off	Blue Ribbon Cable Interface Cable Connection	Check/Replace Blue Ribbon Cable. Check the Interface Cable Connection between the Interface Board and the GSP Board. Replace the Interconnect Board or GSP Board if necessary.
Will not spin and DC drive yellow Watchdog LED is Off	Interface Cable Connection	Check the Interface Cable Connection between the Interface Board and the GSP Board. Replace the Interconnect Board or GSP Board, if necessary (the red blinking LED on the GSP board is the watchdog signal).
Will not spin and DC drive red Fault LED is on	Various	Verify the watchdog LED and the Torque LED are on. Replace drive unit, if necessary.

Symptom	Possible Cause	Remedy
CRT faulty display / no display	Verify the power cable is properly connected and ensure that all necessary power switches are "ON."	If the CRT has power, see if contrast and brightness can be adjusted to produce any display. Failure to produce any image (even a blank screen) indicates the CRT is probably defective. <i>Refer to "CRT Adjustment" page 2-35.</i>
		Verify the CRT cable is properly connected.
		Verify other computer operations are functioning. Does the keypad "Beep?" If so, the problem is probably NOT in the GSP Board.
		If the CRT will produce some kind of display, correct or not, the CRT or GSP Board is defective. One or the other will have to be replaced to make a determination.
Continuous Beep during start up	Program Cartridge	This is an indication that program software is not correctly installed on the GSP Board. Switch off the balancer and correct program cartridge installation. If the program cartridge still provides a continuous beep, verify that all of the pins are straight at the program cartridge connection. If a continuous "beep" is heard after cartridge installation has been verified, exchange the program cartridge or troubleshoot the GSP board.
Keypad is not responding	Blue Ribbon Cable	When the keypad is not responding, check that the keypad cable is connected to the knobs board (GSP9702) or knob interconnect board (GSP9712).
	Keypad Assembly, Knobs Board, Knobs Board Cable to the GSP Board, GSP Board	If the connections are good, then the problem is in either the keypad assembly, knobs board, or GSP Board. If the keypad assembly checks good, substitute the knobs board and/or the cable to the GSP board. If the problem persists, substitute a good GSP board.
GSP Board Failure	AC/DC power supply	Verify the DC power supply voltages using the pads on the GSP board.
	Cable/Power Connections	Verify that all cable and power connections are good. A lockup or failure that occurs with console vibration indicates a cable may be partially cut into by sharp sheetmetal edges.
	Program Cartridge Installation	Verify the program cartridge is installed properly.
"Memory Recall Error"	There was an error in reading permanent memory.	To correct this error message, enter "Setup." The setup items will be set to their default. Set up the system and select "Store Setup." Complete all calibration procedures as described in the GSP9700 Operations Manual, 4202T. If the message reappears when the computer has been turned off and then back on, then there may be a permanent memory problem that requires further service.
	A new cartridge has been installed that requires rearrangement of the permanent memory.	To correct this error message, enter "Setup." The setup items will be set to their default. Set up the system and select "Store Setup." Complete all calibration procedures as described in the GSP9700 Operations Manual, 4202T. If the message reappears when the computer has been turned off and then back on, then there may be a permanent memory problem that requires further service.
	The GSP9700 GSP board was replaced.	To correct this error message, enter "Setup." The setup items will be set to their default. Set up the system and select "Store Setup." Complete all calibration procedures as described in the GSP9700 Operations Manual, 4202T. If the message reappears when the computer has been turned off and then back on, then there may be a permanent memory problem that requires further service.

Symptom	Possible Cause	Remedy
Home pulse error	pre-1.2 software	Install 1.2 before assuming any home pulse errors are due to encoder board components or adjustments.
“No Spindle Rotation Detected” Error	DC Motor Drive, 232-115-1	Verify the GSP9700 voltage requirements of 230 VAC +/- 10% are being met. With the unit unplugged, turn the shaft both directions by hand. If it is hard to turn in either direction and is not when the motor is disconnected from the drive, then the drive is defective. Replace it with a Revision “G” or higher drive. Check for continuity within the motor. When disconnected from the DC drive, lead to lead should measure approximately 5 - 15 ohms. Either lead to the motor case should be open, infinite ohms.
Erratic spindle encoder signal detected	Encoder out of adjustment or dirty	Adjust encoder, verify encoder wheel is clean
Multiple home pulses detected	Encoder out of adjustment or dirty	Adjust encoder, verify encoder wheel is clean
Spindle Overspeed Detected Error / Excessive Time to Reach Correct Rotation Direction Error	Two Motor Leads are Reversed at the DC Motor Drive	You may also notice that in the motor drive tests, the torque control tests seems to work fine and the speed control test will only engage the motor temporarily. This indicates that the motor leads are exchanged. One motor brand will have a red and black wire coming out of it and the other will have two black wires coming out of it. <b>When there is a red and black lead, the red lead goes on top. If there are two black leads, the one marked A2 goes to the top.</b> Correct rotation for a load-roller spin is CCW (top of tire moves toward you) and CW for balance-only spin
“Excessive time to minimum speed” Error	“Servo Stop” calibration	Recalibrate the “Servo Stop,” then proceed with the other calibrations.
AC/DC power supply failure	No 220 VAC input.	Look at the back of the unit to verify the 220 VAC fan is operating. Verify electrical power is being supplied from the AC power outlet. If AC power is present at the outlet, then, the power supply, power supply fuse, or possibly the power selector switch could be defective.
	Interconnecting wire terminations and switch operation	Troubleshooting the power circuit verifying the proper connection of all wire connections and switches. Replace power supply if necessary.
Sensors fail	Interconnect board	If the interconnect board is suspected of causing the failure of any external device, visually inspect the board for connection problems and, if none are present, substitute a good interconnect board. Verify the GSP cable connection because this connector can appear to be connected when it is not completely seated.
Air valves fail	Interconnect board	If the interconnect board is suspected of causing the failure of any external device, visually inspect the board for connection problems and, if none are present, substitute a good interconnect board. Verify the GSP cable connection because this connector can appear to be connected when it is not completely seated. To determine whether the air valves or the interconnect board air valve outputs are bad, try reversing air valve cables or plug in a known good air valve while manually controlling the valves on the air valve diagnostic screen.
Quick-Thread® works intermittently	Software	Check the LED's on the DC motor drive. If the two green LED's come on for a short time and then go off (using 1.0 or lower), the problem is software related. Upgrade to latest software.  Quick-Thread® is not designed to remove a wingnut that is fully tightened. You should loosen the wingnut one or two revolutions before starting Quick-Thread®. Also, keep the threads on the spindle and the cones lubricated.
	Foot pedal sSwitch adjustment	Verify proper operation of the foot pedal switch. Replace if necessary. The switch should actuate simultaneously or slightly before the brake pad applies pressure to the spindle pulley.

Symptom	Possible Cause	Remedy
Setup not storing	Operator error	Items in "setup" will not be stored unless the "Store Setup" key is selected when exiting.
Excessive fan noise		Add qty. 8 of a 77-269-2 washer to the fan mounting screw. Put 2 washers per screw between the fan and the balancer.
"Airbag is not filling up to expected pressure" error	pre-1.2 software	1.2 or later software allows more time to reach expected pressures. Assuming line pressure has been checked, install 1.2 before assuming that this error is due to faulty air components. Use the "loaded runout air components screen" within the service mode to check for air components leaks. Check for small leaks, using a soapy water solution. Small leaks can cause the airbag to deflate in steps, rather than all at once. Verify that output pressure is at 90 psi.
Air bag turns on and off during a loaded spin	RPM dropping below 30 during loaded spin.	If spindle speed drops to 30 RPM during the loaded spin, microprocessor U1 on the interconnect board shuts off the air valves for safety reasons. Above 30 RPM, the bag can inflate. If bag begins to inflate and spindle speed drops below 30 RPM due to resistance, the bag will deflate, spindle speed will increase, the bag will inflate, etc. Assuming no mechanical binding or DC drive problems this could be encountered with pre-1.2 software using large tires with soft tread or under inflated large tires. Version 1.2 reduces load to large tires to allow drive to maintain 90 rpm for the spin.
Force variation reading is a negative or wildly wrong amount.	Air system leak	Software controls air pressure build-up in the bag to two distinct settings to obtain the tire stiffness. Once the "fill" valve shuts off for each of these settings, it is presumed that the air is not leaking during the measurement. If it is the stiffness calculation will be wrong as well as the force variation results. Use leakdown test on the air function diagnostics screen to pinpoint the problem. Version 1.2 or later software has air leak detection during the spin so that an error message will be shown rather than bad force readings.
Force variation does not repeat.	Rubber build-up on load roller tape.	Clean tape with rubber buffer and wire brush, or replace tape. Verify roller runout is less than 0.005 inch.
"Spinning too often, give me a rest" message	pre-1.3 software	Install version 1.3.x or newer software.
"Assertion error / malloc error"	Memory bug	Install version 1.3.x or newer software.
Fails 3 spin calibration	Defective transducer	Check the condition of the ceramic balls. If a force transducer set screw seems too loose, replace it with longer screws or use Loctite on the existing screws. <i>Refer to "Force Transducers," page 2-22.</i>
Fails servo-stop calibration	DC Drive motor or operation error	<i>Refer to "DC Motor Drive," page 2-61 and "Servo Stop Calibration Error Codes," page 4-6.</i>
Fails inner Dataset® arm calibration	Defective Hall effect sensor	<i>Refer to "Inner Dataset® Arm," page 2-1, "Dataset® Arm Sensors," page 3-8, and "Inner Dataset® Arm Calibration Failure," page 4-3.</i>
Fails outer dataset® arm calibration	Defective Hall effect sensor	<i>Refer to "Outer Dataset® Arm," page 2-3, "Dataset® Arm Sensors," page 3-8, and "Outer Dataset® Arm Calibration Failure," page 4-4.</i>
Fails load roller calibration	Defective Hall effect sensor	<i>Refer to "Load Roller," page 2-7, "Loaded Runout Sensor," page 3-9, and "Load Roller Calibration Error Codes," page 4-6.</i>
ALU balance spin repeatability (wheel remount)	Operator error (for wheel remount repeatability testing)	Since weight planes are closer, weight placement is more critical. <i>Refer to "Mechanical mounting repeatability," page 4-18.</i>

---

## Balance/Force Non-Repeatability Flowchart

Before beginning any tests, always check for any foreign objects under the balancer (ex. wheel weights). Check the floor conditions. Do not place a balancer on or across any cracks.

Running a Quick Cal Check (press <start> from logo screen):

Always select "Show Weights" so you can view the actual numbers. Verify that cal weight is tight. Verify that there are no cones on the shaft.

Spin four times with the cal weight on the outer plane. Immediately after a fresh calibration, the balancer should read 4.31 oz. (+/- 0.05) on the outer plane and 0.00 oz. (+/- 0.05) on the inner plane.

Weight amount repeats to within 0.05 on either plane, but it is out of the tolerance:

Repeat the 3 spin calibration, making sure the cal weight is tight on all steps. Verify that hood is not shaking during the cal steps or during this test. Prior to re-calibrating, record the repeatable (but out of tolerance) weight amount for possible future reference. Also, record the left and right magnitudes shown on the "show cal data" screen. This will help determine if there is a drifting force transducer. Individual force transducers data can be viewed while in Service Mode by two methods:

View outputs from last cal or after re-calibrating:

Select "Cal" / "Show Cal Data." Left and right transducer magnitudes for cal spin 2 are shown as items 3 and 9. Magnitudes for cal spin 3 are shown as items 5 and 11.

View outputs for a spin:

From the Balance screen, select "balance bare rim."

Enter the dimensions A=224 / W=4.9 / D=14.0" (set automatically if using pre 1.3 software).

Use on-screen knob to select "no blind."

Push reset twice.

From the Logo screen, select "Diagnostics," and hold down the <Stop> key as you select "Force Sensors."

Spin with cal weight on left side of hub.

Look at the 1st Harmonic "mag" (magnitude) for the left and right force transducers.

NOTE:	Balancer screen steps are required only if you wish to see the weight values caused by force transducer magnitudes.
-------	---

Transducer values should not drift by more than 1%. It may be necessary to record values for a short time to locate a "drifting" transducer.

NOTE:	When using either method to check drift, mark the hole used to start cal (method 1) or spin with (method 2) and use that same hole when later returning for the second test.
-------	--

Ambient temperature must be close to the same between drift checks. If not, normal temperature effects on the force transducer elements will be mistaken for drift.

Newly installed transducers may "settle in" for a week after being compressed. Calibration may be required daily for the first week.

If calibration fails, refer to "Calibration Data Error Codes," page 4-1.

Weight amount doesn't repeat (greater than 0.05 between any spins):

Repeat the 3 spin calibration, verifying that the cal weight is tight on all steps.

Verify that the black channel assembly vibration structure (GSP9702 only) touches only the red wrapper (tub) at the four mounting bolts. Use a business card to check for clearance between vibration structure and wrapper at all locations.

Check the spindle clearance at the wrapper.

Verify the belt access cover is not touching the motor mount bolts.

Verify that storage pegs are not touching vibration structure.

Check for any debris between the vibration structure and wrapper (ex. wheel weights, valve stems, etc.)

Check for loose force transducers.

Check for brake pad clearance at the pulley.

Check for the hood rubbing in various places (weight tray, console, load roller arm). If it is suspected that the hood rubbing on the weight tray is the problem, remove the weight tray and repeat the above tests to confirm. Verify that the inner Dataset® arm does not rest on the spindle housing.

If calibration fails, refer to "Calibration Data Error Codes," page 4-1.

Mechanical mounting repeatability:

**Larger rim/tire assemblies may experience more variation in data than smaller assemblies. This should be considered when comparing data.**

**Do not check repeatability using ALU mode, because it is "hyper-sensitive" in comparison to clip-on weight placement. In ALU mode, the diameters are smaller and the planes are closer together compared to standard clip weight balance, therefore any change in re-centering will be amplified compared to when clip-on weight planes are dialed-in.** For example, a wheel that needs 0.25 or 0.50 oz. weights in ALU mode may show zeros in clip-on weight mode. You can also get cases where dynamic imbalance on standard is small, such as 1 oz., and it jumps to 4 or more ounces in ALU, if the planes are close enough together. This does not mean that the assembly has a greater imbalance in ALU mode! All balancers will do this, which is why most balancers have such a hard time hitting zero with one spin using adhesive weights.

Mount a medium size passenger car wheel (14-15 inch). Preferably, use a wheel with which you are familiar.

Verify that all of the above tests have already passed.

Verify that threads are lubed, preferably, with a Teflon containing oil that leaves a DRY Teflon film, such as Super Lube by Loctite. Do not use WD-40.

Check the dimensions to verify that they are accurate. Distance cannot be checked to the wheel, but you can take a cone and place it on the outside of the hub plate. Bring the inner Dataset® out to the cone and step on the foot pedal. You should get approximately 295 mm. For width and diameter, input the wheel dimensions using the Dataset® arms. Check the rim dimensions on the screen for accuracy (compare width to caliper and diameter to rim diameter). Set the balancer for non-rounded readings (override position).



Spin 4 times without the load roller. Do not loosen the wingnut between any of these spins.

The balancer should repeat within 0.05 ounce on each spin. If this test does not pass, check the wheel for debris or water in the tire. You may also want to try another wheel.

If it still does not pass, make sure the wheel dimensions have not changed between spins.

If the wheel dimensions have changed, there is a possible problem with the knob board or calibration of Dataset® (home position). Calibrating the inner Dataset® with the weight tray off and then operating with the weight tray on can cause this. This can cause the Dataset® to have a “hair trigger” and stepping on the foot pedal will store the wrong dimensions.

If it does repeat within 0.05 ounce, rotate the assembly 4 times at 90 degree increments and see that the readings do not change by more than 0.30 ounce from the highest to the lowest. This means that the balancer repeats +/- 0.15 ounce about the true imbalance. If it does not fall within this tolerance, try the procedure again, being very careful to keep the same center. You may want to try a different wheel.

**If ALL readings change, BUT the readings from the first sample data and the second sample data are the same for 0, 90, 180, and 270 degrees, the hub/shaft assembly is not running concentric.** Use a dial indicator to check for runout on the hub face and on the shaft. Runout on the hub face should not exceed 0.0015 inch. Runout on the shaft should not exceed 0.0015 inch. If runout exceeds these limits, remove the threaded hub/shaft assembly and inspect for any debris or nicks on the tapered mounting surfaces. Remove any nicks using a fine grit stone, removing only the raised portion of the metal around the nick. Do NOT use sandpaper! Clean parts and lightly oil before reassembling and re-measuring runout. If the problem is still not resolved, call the service center and special replacement parts can be used.

NOTE:	If this and all preceding tests pass, the balancer portion of the GSP9700 is working both electronically and mechanically.
-------	--

**If the imbalance amounts change and the readings from the first sample data and the second sample data are NOT the same for 0, 90, 180, and 270 degrees, the assembly is not being mounted correctly.** Refer to “Mounting the Wheel, Centered on the Spindle Shaft” and “On-Vehicle Wheel Mounting Methods” in the GSP9700 Series Vibration Control System Operations Instructions, Form 4202T for proper mounting techniques.

Possible remaining problems could be force variation problems or rim runout problems.

Check to see if balance measurement repeatability problems are due to the balancer being sensitive to the balancer sliding on the floor (some of the older balancers are more sensitive to this than the recently manufactured balancers). To check this, all that is necessary is to push on the base of the wheel cover and make the balancer slide a half inch on the floor between balance spins (same wheel must stay mounted each spin). If this causes the balance measurements to change by more than 0.15 oz., then bolting the balancer to the floor should be recommended.

#### Force Variation Problems:

All of the above tests must pass.

#### Problems with the load roller.

Hall effect sensors for the load roller and Dataset® arms: Use the calibration bar to check that the sensors repeat the calibration position measurements within expected tolerances. *Refer to "Appendix D - Cal Position Values and Tolerance Checks," page 8-1.*

#### Mechanical problems with the loaded runout measurement system:

Runout of the load roller measured on the aluminum surface at either end of the roller should be manufactured to under 0.005 inch TIR. However, because of the digital filtering of the GSP9700, runouts in the roller as much as 0.015 inch will cause only a minor change in the measured values.

Air components - see Help from the Lab on the Hunter Engineering Website. Verify that there are no significant air leaks in the system. To check, use the air components diagnostic screen. Mount a wheel and fill the bag to 60 psi. Wait one minute, then record the pressure (normal relaxation of the rubber causes a pressure drop in this first minute). Wait 30 seconds more and check that the pressure is within 0.5 psi of the recorded pressure. The quick exhaust valve located under the airbag will sometimes exhaust air due to a leak upstream. One way to help in finding the leak is to remove the air hose going into the quick exhaust and plug it. If the system still fails the leak test, then a leak must be found upstream from the quick exhaust.

#### Rim runout problems:

Inner or outer Dataset® problems - mechanical, electrical, or procedural.

Weight tray rubbing on Dataset® arm. Binding on roller on Dataset® arm.

#### Dataset® Arm repeatability:

Check mechanical adjustments. *Refer to "Dataset® Arms," page 2-1.*

Electrical problems. *Refer to "Hall Effect Sensors," page 2-12.*

Verify that Dataset® arms are being used properly. *Refer to "GSP9700 Series Vibration Control System Operation Instructions," Form 4202T.*

## 5 .Appendix A – Part Numbers

<b>NAME</b>	<b>GSP9702 NUMBER</b>	<b>GSP9712 NUMBER</b>
GSP Board	45-715-3	45-715-3
Knobs Board	45-779-1	N/A
Knob interconnect board	N/A	45-953-1
Spindle Encoder Board	45-863-1	45-863-1
Interconnect Board	45-825-1	45-825-1
CRT Assembly	227-80-2*	227-74-2
25W Power Supply	232-90-2	232-90-2
Keypad	18-383-2	18-441-2
Hub/Shaft Assembly	97-397-3	N/A
Spindle Drive Assembly	N/A	105-406-1
Hall Effect Sensor	125-299-1	125-299-3
Magnet Assembly	176-35-1	176-35-1
Force Transducer	109-87-3	109-97-3
Air Bag	98-334-2	98-283-2
DC Motor Drive	232-115-1	232-115-1
Program Cartridge Module (U.S. Domestic)	G01-0110000-1	G01-0110000-1
* May need to order as a 20-1448-1 if removing a Wells-Gardner monitor.		



# 6 .Appendix B – Pneumatic System

---

## Air Component Function (GSP9702)

Air enters through hose (54) and passes through filter (53). This filter will automatically drain water out of the bottom of the filter bowl onto the floor if there is any water in the air supply. Air then enters the balancer and passes through a non-adjustable regulator (36), which has been factory preset to 90 psi. The air next goes through valve (37). This valve has a 12 volt coil which opens the valve when the coil is energized and a spring in the valve which closes the valve when power is removed from the coil. Next, the air goes into a cross fitting (and can then go to one of the following three places: 1) it can go through fitting (33) and then to a pressure transducer on the interface PC board, 2) it can go to valve (38) however this valve is always closed when valve (37) is open, or 3) the air can go to the quick exhaust valve (45) and then into the air bag (21). Valve (38) has a 12 volt coil which closes the valve when the coil is energized and a spring which opens the valve when power is removed from the coil. Valve (38) is de-energized to exhaust air from the air bag. The quick exhaust valve (45) passes the air into the air bag from air tube (49) when the pressure in air tube (49) is high and the quick exhaust valve will exhaust the air from the air bag out through exhaust silencer (48) if the pressure in air tube (49) is low.

The three states of the air components are as follows:

### **Filling air bag**

Valve (37) open and coil energized

Valve (38) closed and coil energized

Quick exhaust valve (45) passing air from tube (49) into air bag

### **Taking measurements-air blocked in air bag**

Valve (37) closed and coil de-energized

Valve (38) closed and coil energized

Quick exhaust valve (45) passing air from tube (49) into air bag

### **Exhausting air bag**

Valve (37) closed and coil de-energized

Valve (38) open and coil de-energized

Quick exhaust valve (45) exhausting air from air bag through silencer

#### **NOTE:**

*Refer to Inflation Station System Schematic, page 6-5. If Control Valve "B" leaks air, it will cause the quick exhaust to shift and subsequently leak. Therefore, if the quick exhaust is leaking, Control Valve "B" should be checked (and replaced if necessary) before replacing the quick exhaust.*

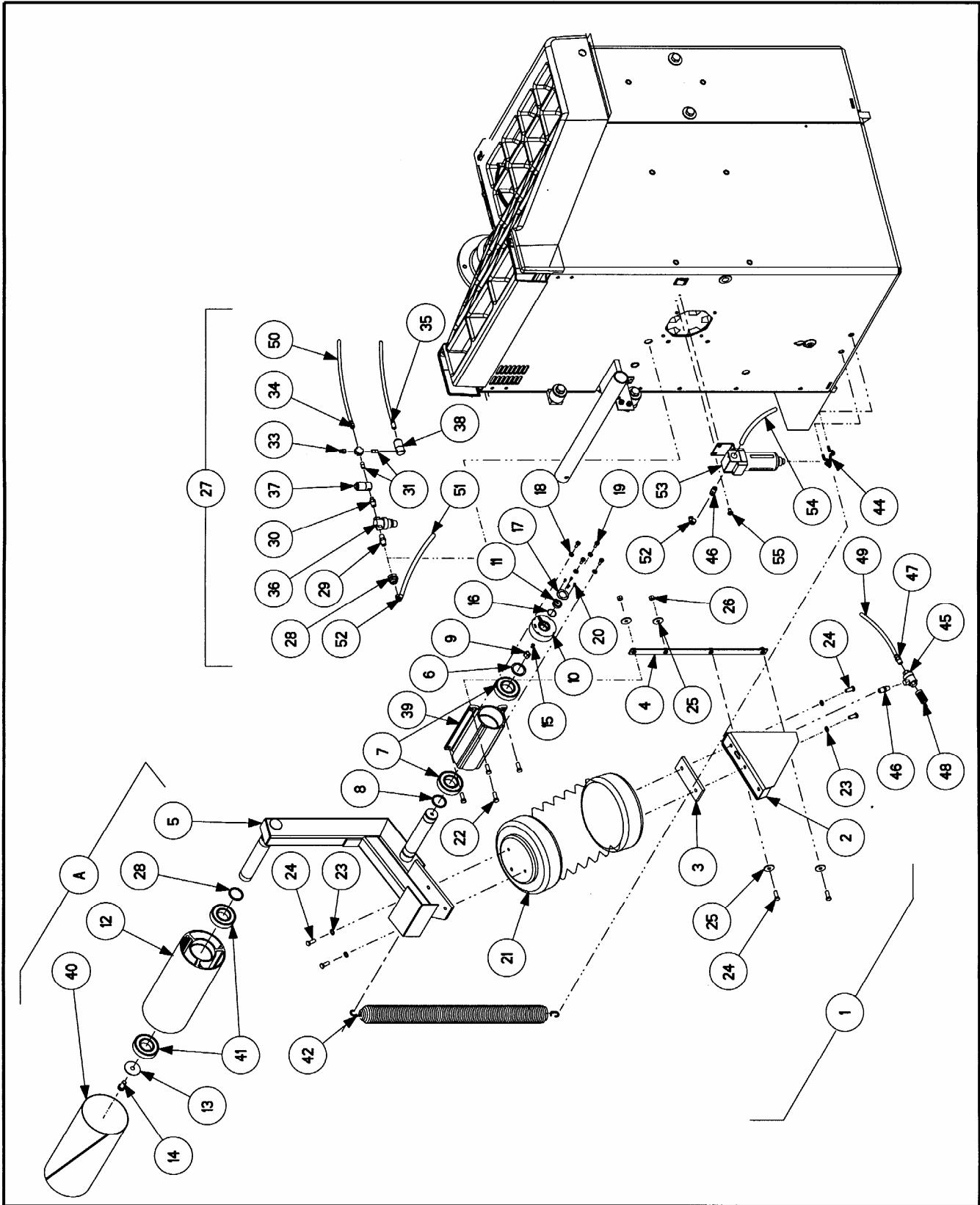

GSP9702

---

## Air Component Function (GSP9712)

Air enters through hose (67) and passes through filter (58). This filter will automatically drain water out of the bottom of the filter bowl onto the floor if there is any water in the air supply. Air then enters the balancer and passes through a non-adjustable regulator (46), which has been factory preset to 90 psi. The air next goes through valve (48). This valve has a 12 volt coil which opens the valve when the coil is energized and a spring in the valve which closes the valve when power is removed from the coil. Next, the air goes into a tee fitting (and can then go to one of the following two places: 1) it can go through fitting (53) and then into a pressure transducer on the interconnect board, or 2) it can go to valve (57). Valve (57) has a 12 volt coil which shifts the valve when the coil is energized and a spring that returns it to the normal position when power is removed from the coil. Valve (57) can be thought of as a "selector" to choose either the tire or airbag and valve (48) is used to add or hold air. The quick exhaust valve (16) passes the air into the air bag from air tube (64) when the pressure in air tube (64) is high and the quick exhaust valve will exhaust the air from the air bag out through its exhaust silencer if the pressure in air tube (64) is low.

The four states of the air components are as follows:

### **Fill Tire/Exhaust Air Bag**

Valve (48) open and energized

Valve (57) de-energized

Air flows to tire and air bag exhausts through quick exhaust (16)

### **Fill Air Bag/Exhaust Tire**

Valve (48) open and energized

Valve (57) energized

Air flows to air bag and tire exhausts through valve (57)

### **Read Tire/Exhaust Air Bag**

Valve (48) closed and coil de-energized

Valve (57) de-energized

Pressure transducer reads tire and air bag exhausts through quick exhaust (16)

### **Exhaust Tire/Read Air Bag**

Valve (48) closed and coil de-energized

Valve (57) energized

Pressure transducer reads air bag and tire exhausts through valve (57)

**NOTE:**

*Refer to Inflation Station System Schematic, page 6-5. If Control Valve "B" leaks air, it will cause the quick exhaust to shift and subsequently leak. Therefore, if the quick exhaust is leaking, Control Valve "B" should be checked (and replaced if necessary) before replacing the quick exhaust.*

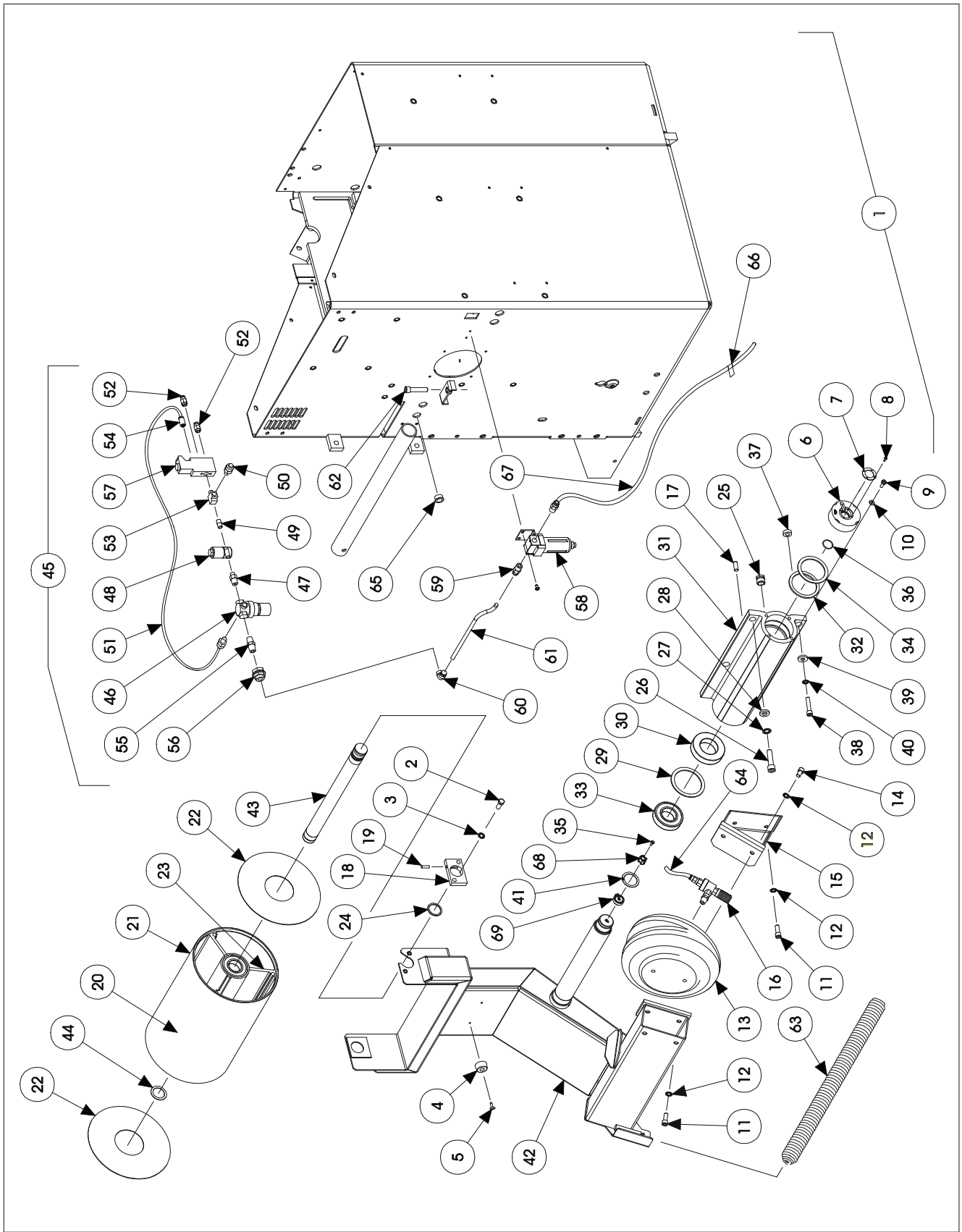

GSP9712



# Inflation Station System Schematic

## Fill Air Bag

When both control valves are "ON," the air pressure sensor is reading the air bag pressure and filling the air bag. If the bag does not inflate, remove the line at the quick exhaust valve or outlet of control valve "B" and retest. If no air is present, remove the air pressure sensor line and retest. Replace valves or regulators as necessary.

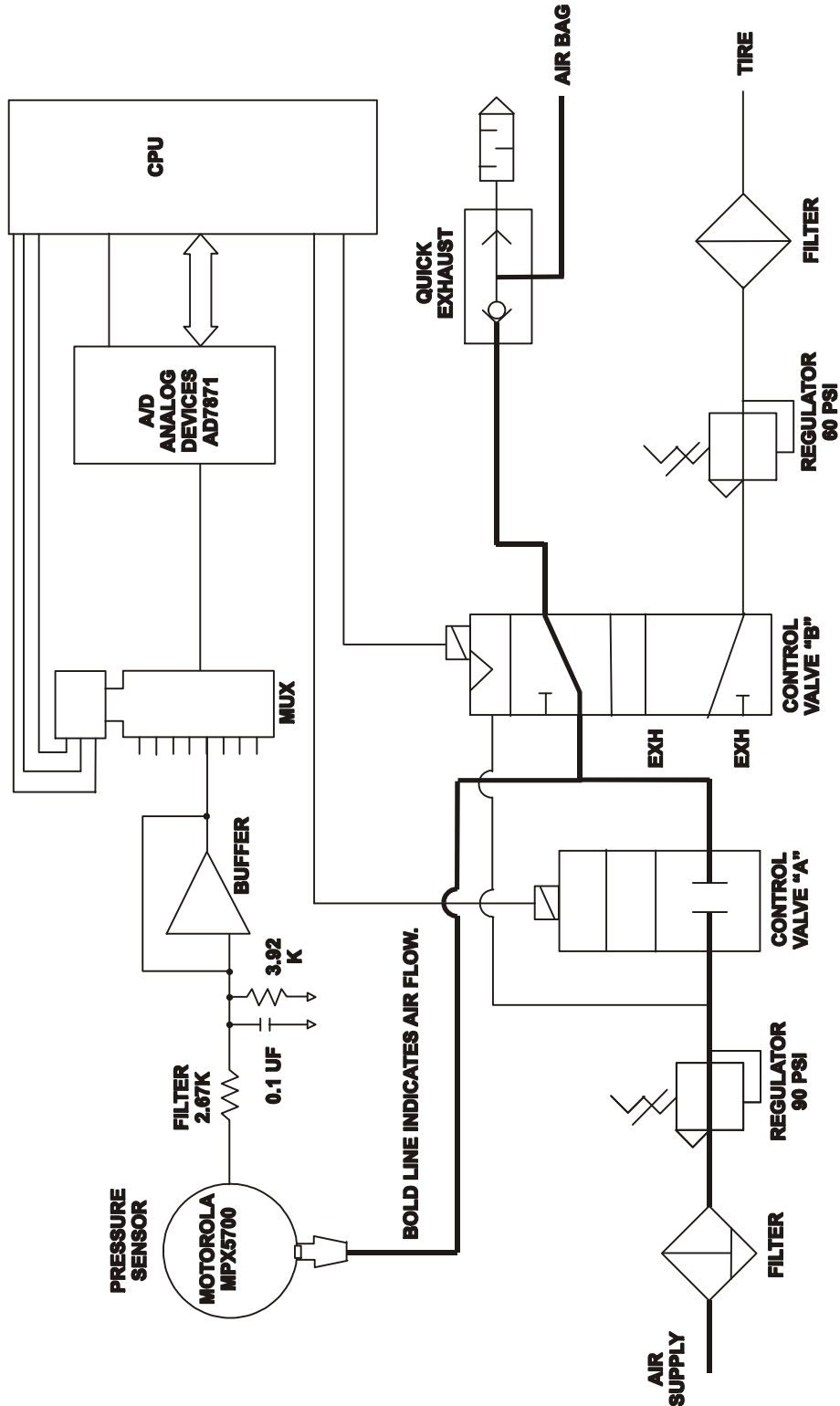

**NOTE: CHECK CONTROL VALVE "B" FOR LEAKS (AND REPLACE IF NECESSARY) BEFORE REPLACING THE QUICK EXHAUST.**

## Fill Tire

When control valve "A" is "ON" and control valve "B" is "OFF," the air pressure sensor is reading the tire pressure and filling the tire. If the tire does not inflate, remove the line at the 60 psi regulator or outlet of control valve "B" and retest. If no air is present, remove the air pressure sensor line and retest. Replace valves or regulators as necessary.

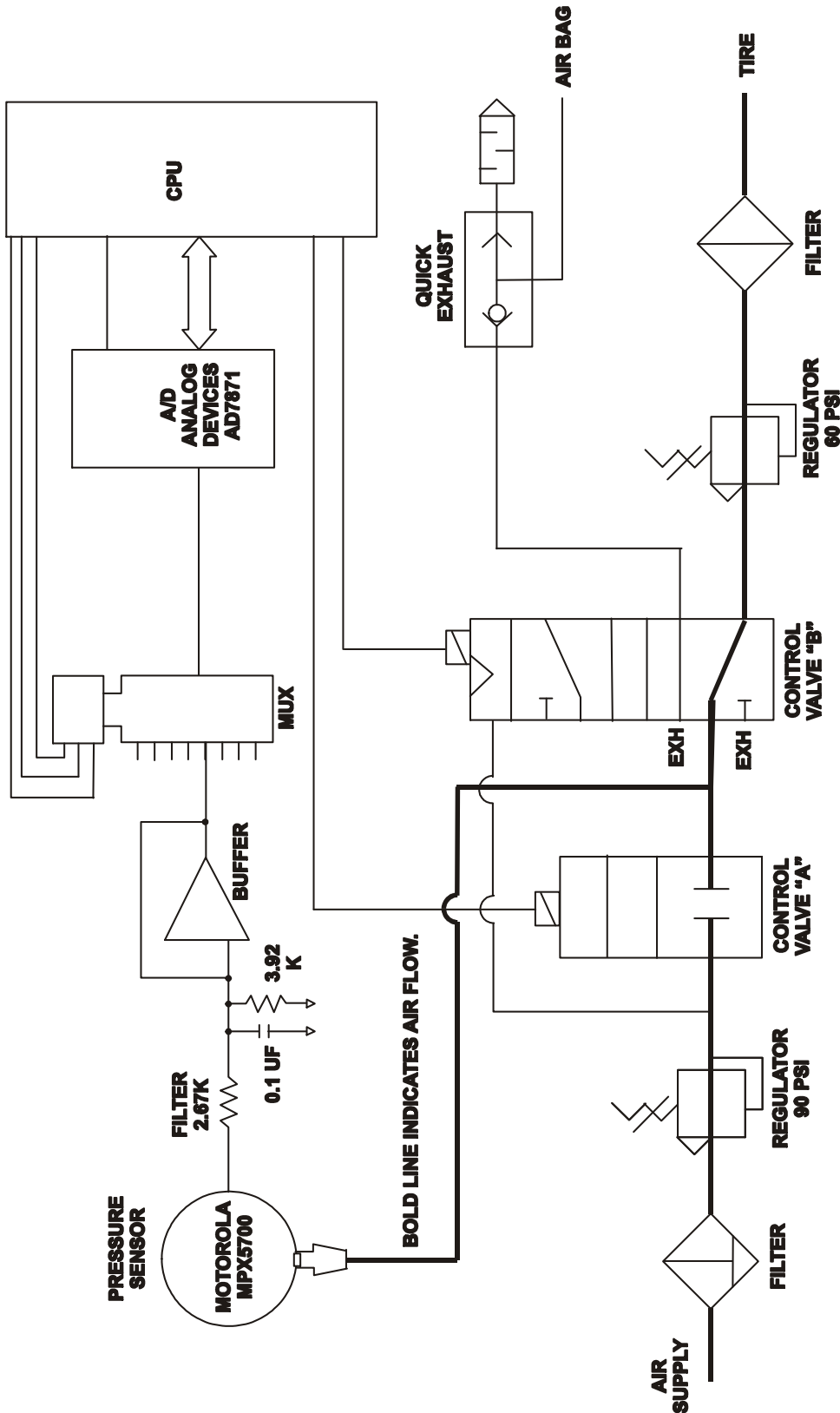

**NOTE: CHECK CONTROL VALVE "B" FOR LEAKS (AND REPLACE IF NECESSARY) BEFORE REPLACING THE QUICK EXHAUST.**

## Read Air Bag

When control valve "A" is "OFF" and control valve "B" is "ON," the air pressure sensor is reading the air bag pressure or deflating the tire.

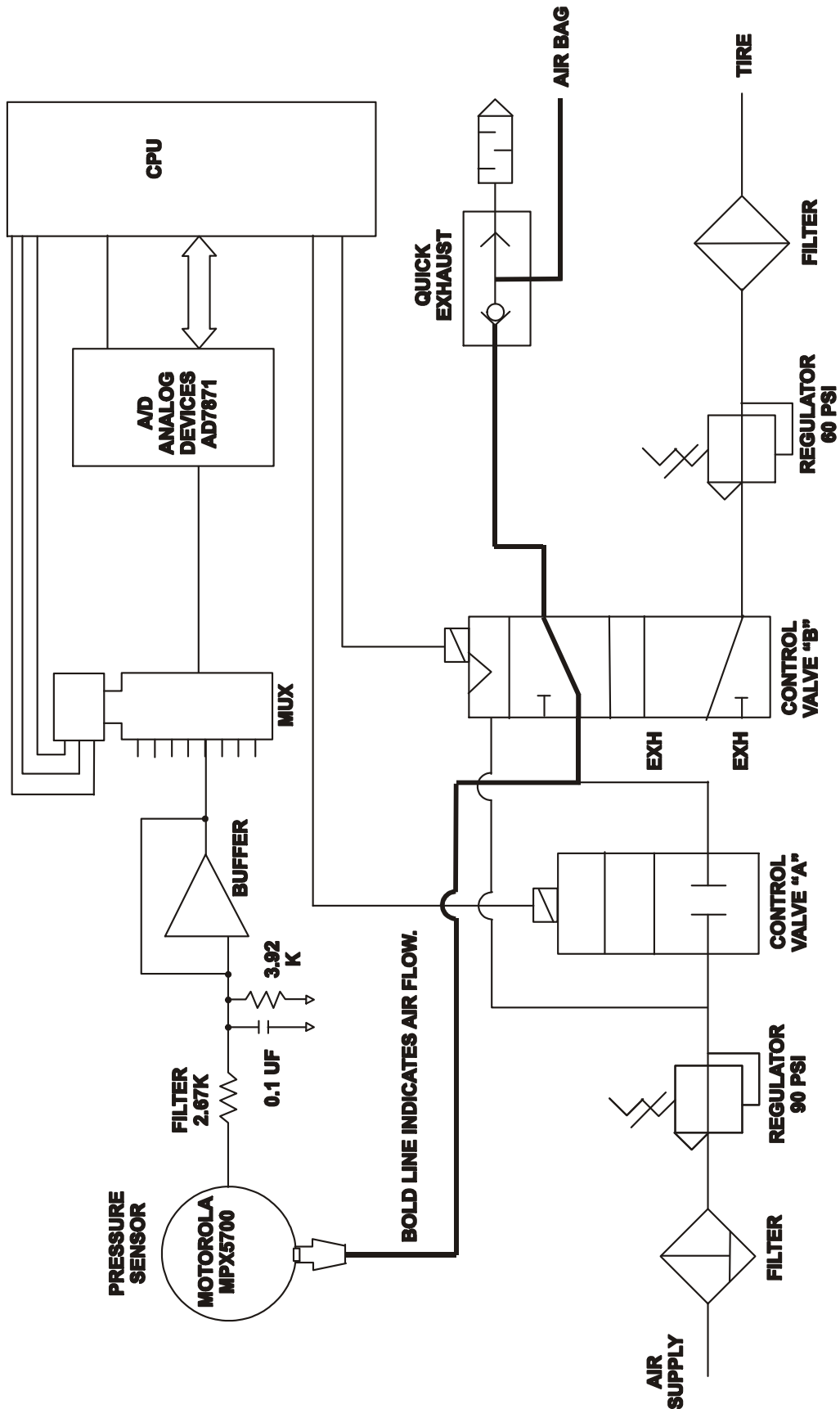

**NOTE: CHECK CONTROL VALVE "B" FOR LEAKS (AND REPLACE IF NECESSARY) BEFORE REPLACING THE QUICK EXHAUST.**

## Read Tire

When both control valves are "OFF," the air pressure sensor is reading the tire pressure. If the tire pressure display does not come up on the screen when the inflation hose is connected to a tire, disconnect the air pressure sensor line, connect the inflation hose to a tire, and verify that air pressure is coming back to the sensor. If no air pressure is present, disconnect the air line at control valve "B" to check for air pressure there.

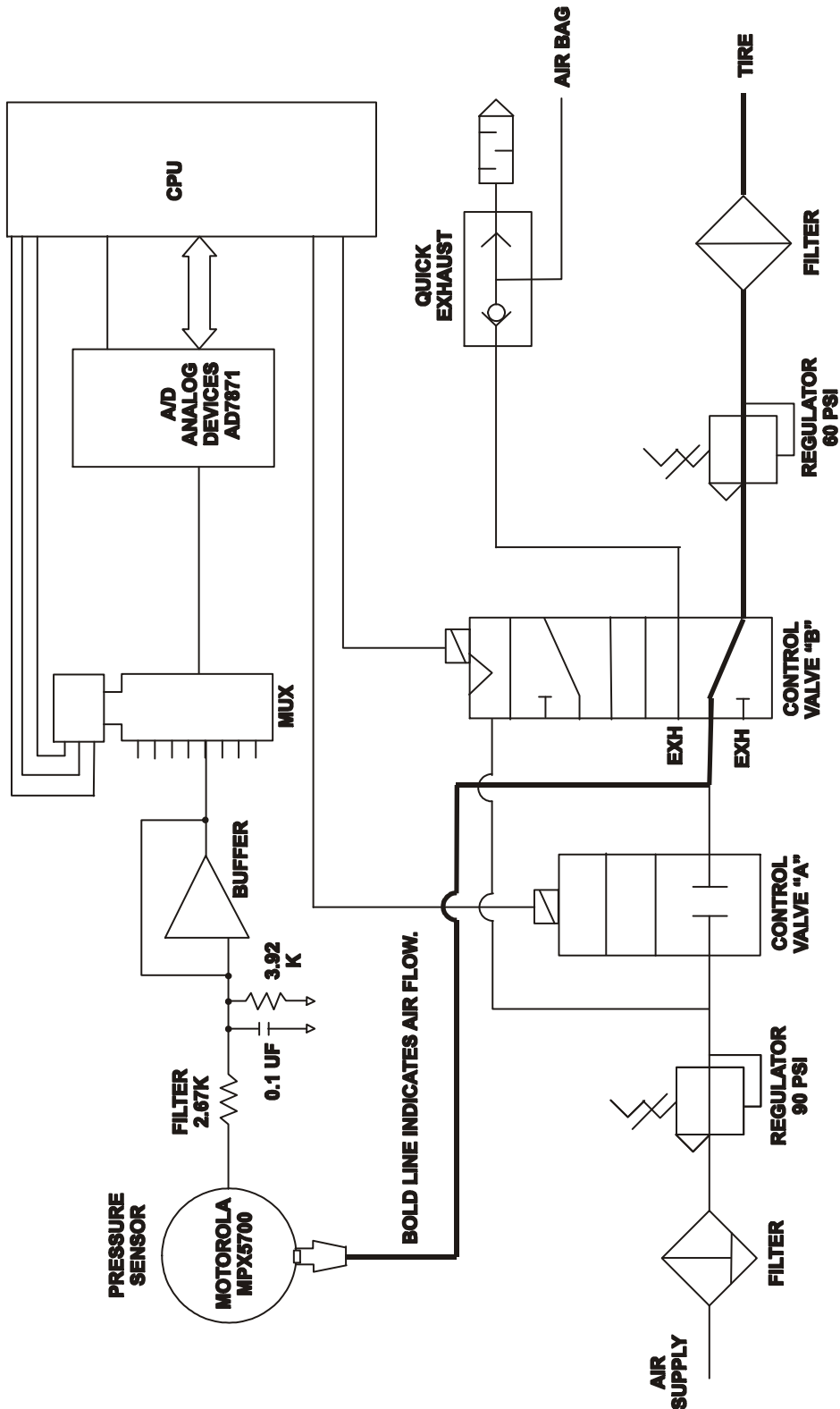

**NOTE: CHECK CONTROL VALVE "B" FOR LEAKS (AND REPLACE IF NECESSARY) BEFORE REPLACING THE QUICK EXHAUST.**

# 7 .Appendix C – Interface Board Schematic, 1-1-297

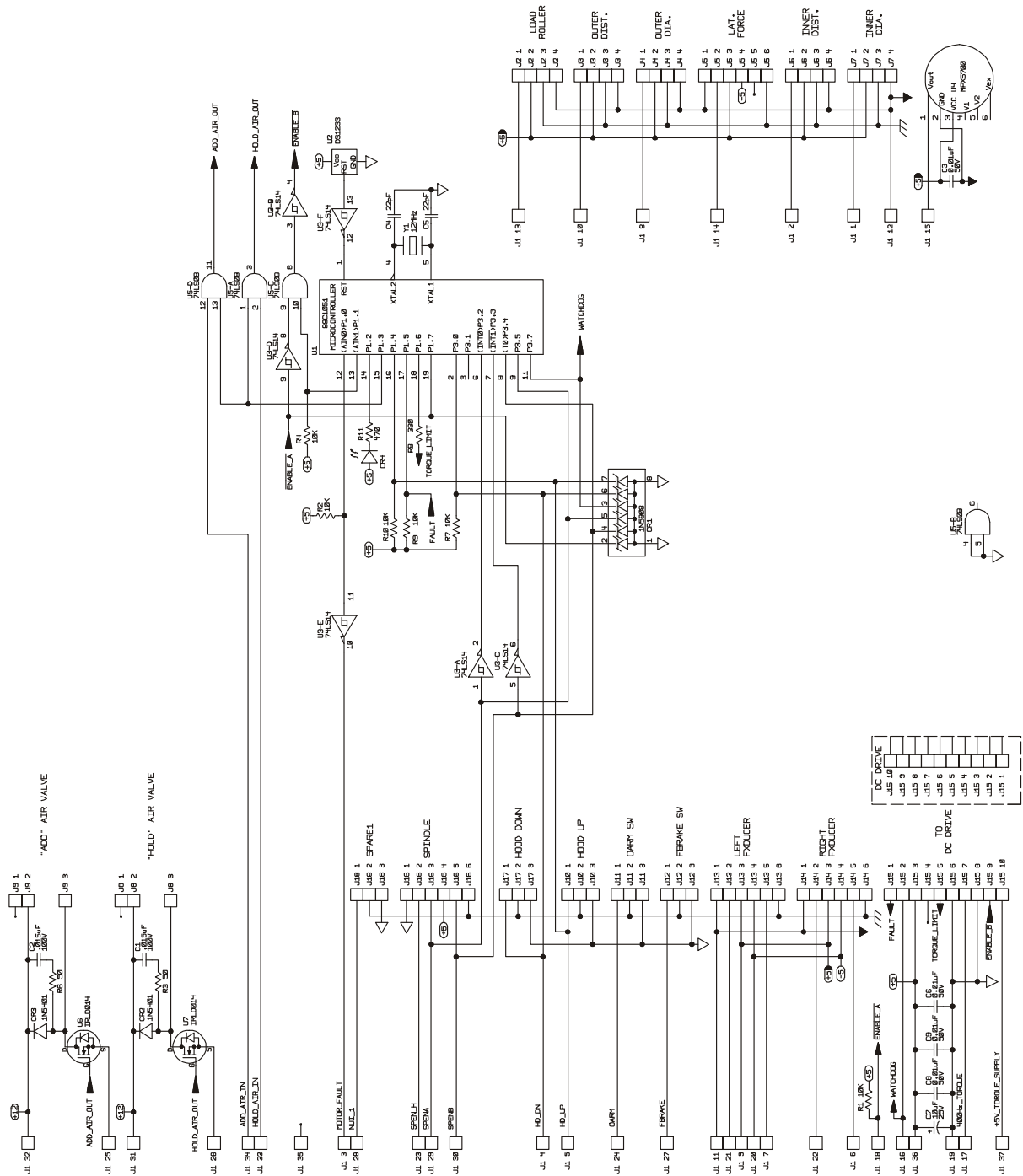



# 8 .Appendix D - Cal Position Values and Tolerance Checks

**NOTE:** The calibration values shown below are displayed only after calibration of a particular Dataset® arm by accessing the softkey “Show Calibration Data” on the calibration screen while in diagnostics mode. These values are available only as long as power is left on after calibrating.

“Service Mode Diagnostics” can be toggled by holding down the “K2” and “K3” softkeys simultaneously while pressing the reset button twice. The logo screen title should change to “GSP9700 Service Mode.” Select “Calibrate” from the logo screen. Select an item to calibrate, then press “Begin Procedure.”

Example:

Suppose the inner Dataset® fails calibration. Go to the “Service Mode” and enter the inner Dataset® procedure, then press “Show Calibration Data.” Insert the values displayed on the screen to the left of “01, 02, and 03” into the formulas used to check sensor movement during the cal procedure.

01 (Va) is 2625  
02 (Vb) is 3510  
03 (Vc) is 4615

For further explanation of Hall effect calibration points, refer to “Data Acquisition Circuits,” page 3-6.

To check variable 01 with formula  $Va = Vb - 900$  {3510-900=2610}. In this case, Va is a valid number. It is within the +/- 90 tolerance of 2610 allowed.

To check variable 02, it has a typical value of 4000, with a tolerance of 400. In this case it is 3510, too low.

To check variable 03 with formula  $Vc = Vb + 900$  {3510+900=4610}. In this case, Vc is a valid number. It is within the +/- 90 tolerance of 4610 allowed.

In the above example, the sensor appears to be responding correctly, even though Variable 02 (Vb) is too low. This usually indicates a centering problem likely related to the way the sensor itself or the magnet locator is mounted. This can be verified by inserting the values for Va and Vc into the centering formula.

If the values appear to be changing very little or not at all, this would indicate a problem with that sensors’ circuit, see the troubleshooting section earlier in this manual.

If Vb looks good, but Va and/or Vc is wrong, check your steps in the cal procedure first, then look for mechanical problems related to the arms movement. After that, this would indicate a problem with that sensors’ circuit, see the troubleshooting section earlier in this manual.

Variable Vb is the most important value to verify, so check it first. It is related to where the sensor is centered in its travel. Variables Va and Vc are values derived from the sensors movement during the cal procedure.

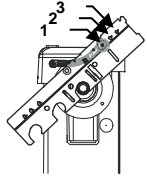
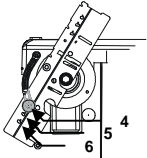
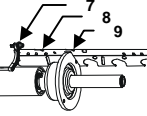
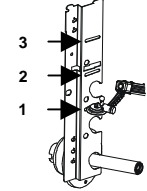
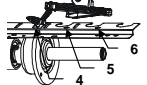
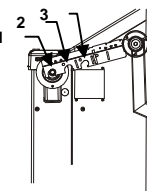
	Cal step	Cal variable displayed on screen	Formula used to check sensor movement	Tol. ±	"Centering" check
 Inner Dataset® radial sensor, upper positioning	1	01: cal pos "Va":	(Vb-900)	90	Vb should be: $Va + \{(Vc - Va) \times 0.500\} \pm 90$
	2	02: cal pos "Vb":	4000	400	
	3	03: cal pos "Vc":	(Vb+900)	90	
 Inner Dataset® radial sensor, lower positioning	4	07: cal pos "Va":	(Vb-900)	90	Vb should be: $Va + \{(Vc - Va) \times 0.500\} \pm 90$
	5	08: cal pos "Vb":	4000	400	
	6	09: cal pos "Vc":	(Vb+900)	90	
 Inner Dataset® lateral sensor, upper arm positioning	9	24: cal pos "Va":	(Vb-1350)	135	Vb should be: $Va + \{(Vc - Va) \times 0.541\} \pm 125$
	8	25: cal pos "Vb":	4000	400	
	7	26: cal pos "Vc":	(Vb+1140)	114	
Inner Dataset® lateral sensor, lower positioning (not physically measured, computed from previous steps)	x	30: cal pos "Va":	Vb-1350)	135	Vb should be: $Va + \{(Vc - Va) \times 0.541\} \pm 125$
	x	31: cal pos "Vb":	4000	400	
	x	32: cal pos "Vc":	(Vb+1140)	114	
 Outer Dataset® radial sensor	1	01: cal pos "Va":	(Vb-500)	50	Vb should be: $Va + \{(Vc - Va) \times 0.500\} \pm 50$
	2	02: cal pos "Vb":	4000	400	
	3	03: cal pos "Vc":	(Vb+500)	50	
 Outer Dataset® lateral sensor	6	24: cal pos "Va":	(Vb-500)	50	Vb should be: $Va + \{(Vc - Va) \times 0.500\} \pm 50$
	5	25: cal pos "Vb":	4000	400	
	4	26: cal pos "Vc":	(Vb+500)	50	
 Load roller sensor	3	01: cal pos "Va":	(Vb-750)	75	Vb should be: $Va + \{(Vc - Va) \times 0.500\} \pm 75$
	2	02: cal pos "Vb":	4000	400	
	1	03: cal pos "Vc":	(Vb+750)	75	